

EXAMINED BY: <i>Jony Chen</i>	MITSUTECH INTERNATIONAL CORPORATION	FILE NO . CAS-10072
APPROVED BY: <i>David Chang</i>		ISSUE : OCT.21,1999
		TOTAL PAGE : 9
		VERSION : 2

CUSTOMER	ACCEPTANCE	SPECIFICATIONS
----------	------------	----------------

MODEL NO. :

13B30(LED TYPES)

FOR MESSRS :

CUSTOMER'S APPROVAL

DATE :

BY :

MODEL NO . 13B30(LED TYPES)	VERSION 2
--------------------------------	--------------

Polarizer Mode	Backlight	Code value
Transflective	LED	L
Transmissive	LED	M

E	W	13	B	30	G	L	Y
---	---	----	---	----	---	---	---

LCD type + color	Code Value
STN + Yellow-Green	Y
STN + Gray	G
FSTN + White	F

TABLE OF CONTENTS

NO.	ITEM	PAGE
1.	GENERAL SPECIFICATIONS -----	1
2.	MECHANICAL SPECIFICATIONS -----	1
3.	ABSOLUTE MAXIMUM RATINGS -----	2
4.	ELECTRICAL CHARACTERISTICS -----	3
5.	INTERFACE TIMING CHARACTERISTICS -----	4
6.	OPTICAL CHARACTERISTICS -----	5
7.	OUTLINE DIMENSION -----	6
8.	BLOCK DIAGRAM -----	7
9.	DETAIL DRAWING OF DOT MATRIX -----	8
10.	INTERFACE SIGNALS -----	8
11.	POWER SUPPLY -----	9

MODEL NO.	VERSION	PAGE
13B30(LED TYPES)	2	1

1. GENERAL SPECIFICATIONS

1.1 GENERAL SPECIFICATIONS

PLEASE REFER TO :

CUSTOMER ACCEPTANCE STANDARD SPECIFICATIONS :

E U - 0 0 2 A

1.2 APPLICATION NOTES FOR CONTROLLER

PLEASE REFER TO :

CUSTOMER ACCEPTANCE STANDARD SPECIFICATIONS :

E U - 1 0 0

1.3 THIS INDIVIDUAL SPECIFICATION IS PRIOR TO GENERAL SPECIFICATIONS .

2. MECHANICAL SPECIFICATIONS

- (1) NUMBER OF DOTS ----- 128W * 64H DOTS
- (2) MODULE SIZE ----- 93.0W * 70.0H * 14.0D(max) mm
- (3) EFFECTIVE AREA ----- 70.7W * 38.8H mm
- (4) ACTIVE AREA ----- 65.25W * 32.61H mm
- (5) DOT SIZE ----- 0.48W * 0.48H mm
- (6) DOT PITCH ----- 0.51W * 0.51H mm
- (7) LCD TYPE *
- (8) DRIVING METHOD ----- 1 / 64 DUTY MULTIPLEX DRIVE
- (9) BACKLIGHT * ----- LED , COLOR : YELLOW-GREEN

* PLEASE REFER TO NUMBERING SYSTEM .

3. ABSOLUTE MAXIMUM RATINGS

3.1 ELECTRICAL ABSOLUTE MAXIMUM RATINGS .

PARAMETER	SYMBOL	MIN .	MAX .	UNIT	REMARK
POWER SUPPLY FOR LOGIC	VDD - VSS	0	7.0	V	
INPUT VOLTAGE	VI	VSS	VDD	V	
STATIC ELECTRICITY	—	—	100	V	NOTE (1)
LED POWER DISSIPATION	PD	—	3.6	W	
LED FORWARD CURRENT	IF	—	720	mA	
LED REVERSE VOLTAGE	VR	—	8	V	

NOTE (1) : TEST METHOD AND CONDITIONS :

AFTER CHARGING UP 200 PF CAPACITOR BY STATED VOLTAGE ,
THE CAPACITOR IS CONNECTED WITH INTERFACE PINS OF THE
MODULE .

3.2 ENVIRONMENTAL ABSOLUTE MAXIMUM RATINGS .

I T E M	OPERATING		STORAGE		COMMENT
	MIN .	MAX .	MIN .	MAX .	
AMBIENT TEMPERATURE	-20 °C	70 °C	-30 °C	80 °C	NOTE (2), (3)
HUMIDITY	—	85 % RH	—	85 % RH	WITHOUT CONDENSATION
VIBRATION	—	2.45 m/s ² (0.25 G)	—	11.76 m/s ² (1.2 G)	10 ~ 100 HZ XYZ DIRECTIONS 1 Hr . EACH
SHOCK	—	29.4 m/s ² (3 G)	—	490.0 m/s ² (50 G)	10 mSECONDS XYZ DIRECTIONS 1 TIME EACH
CORROSIVE GAS	NOT ACCEPTABLE		NOT ACCEPTABLE		

NOTE (2) : Ta AT -30°C : 48HR MAX .

80°C : 168HR MAX .

NOTE (3) : BACKGROUND COLOR CHANGES SLIGHTLY DEPENDING ON AMBIENT
TEMPERATURE THIS PHENOMENON IS REVERSIBLE .

4. ELECTRICAL CHARACTERISTICS

Ta = 25 °C

VDD = 5.0 V

PARAMETER	SYMBOL	CONDITION	MIN .	TYP .	MAX .	UNIT
POWER SUPPLY VOLTAGE FOR LOGIC	VDD - VSS	—	4.75	5.0	5.25	V
INPUT VOLTAGE NOTE (1)	VIH	H LEVEL	0.7*VDD	—	VDD	V
	VIL	L LEVEL	GND	—	0.3*VDD	V
OUTPUT VOLTAGE NOTE (1)	VOH	H LEVEL	VDD-0.4	—	—	V
	VOL	L LEVEL	—	—	0.4	V
POWER SUPPLY CURRENT FOR LOGIC NOTE (2)	IDD	VDD - VSS = 5.0 V VDD - VO = 9.2 V	—	7.0	—	mA
RECOMMENDED LCD DRIVING VOLTAGE NOTE (3)	VDD - VO ∅ = 10° θ = 0°	Ta = -20 °C	—	9.2	—	V
		Ta = 25 °C	—	9.2	—	
		Ta = 70 °C	—	8.4	—	
LED FORWARD VOLTAGE	VF	IF = 360 mA	—	4.2	4.6	V
LED FORWARD CURRENT	IF	—	—	360	—	mA
LED REVERSE CURRENT	IR	VR = 8V	—	—	200	μA

NOTE (1): APPLIED TO TERMINALS CS1, CS2, R/W, D/I, DB0~DB7, E, RET.

NOTE (2): THE DISPLAY PATTERN IS ALL "ON" / "OFF".

NOTE (3): RECOMMENDED LCD DRIVING VOLTAGE MAY FLUCTUATE ABOUT ±1.0V BY EACH MODULE.

5. INTERFACE TIMING CHARACTERISTICS

PARAMETER	SYMBOL	MIN.	TYP.	MAX.	UNIT	FIG.
E cycle time	t _{CYC}	1000	—	—	nS	1,2
E high level	P _{WEH}	450	—	—	nS	1,2
E low level width	P _{WEL}	450	—	—	nS	1,2
E rise time	t _r	—	—	25	nS	1,2
E fall time	t _f	—	—	25	nS	1,2
Address setup time	t _{AS}	140	—	—	nS	1,2
Address hold time	t _{AH}	10	—	—	nS	1,2
Data setup time	t _{DSW}	200	—	—	nS	1
Data delay time	t _{DDR}	—	—	320	nS	2
Data hold time (Write)	t _{DHW}	10	—	—	nS	1
Data hold time (Read)	t _{DHR}	20	—	—	nS	2

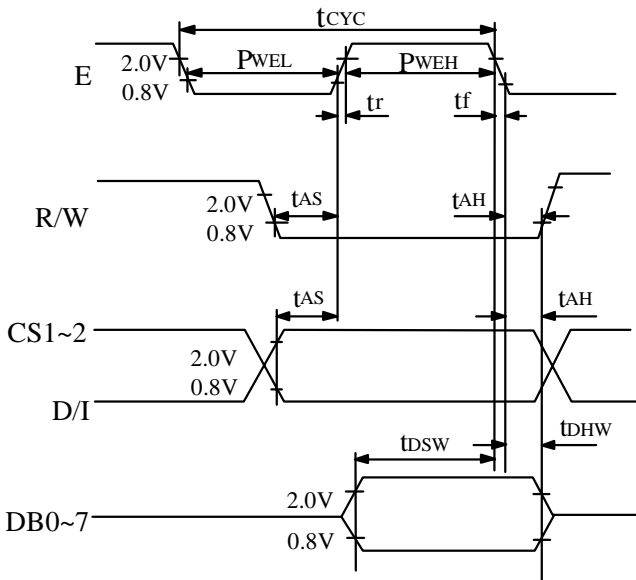

Fig . 1 CPU Write Timing

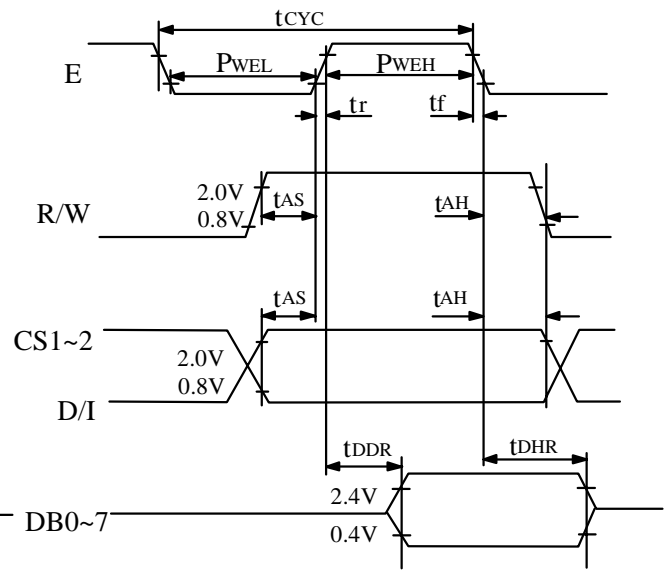

Fig . 1 CPU Read Timing

6. OPTICAL CHARACTERISTICS

Ta = 25 °C

VDD = 5.0 V

VDD - V0 = 9.2 V

I T E M		SYMBOL	CONDITION	MIN.	TYP.	MAX.	UNIT	NOTE
VIEWING AREA	STN	∅2 - ∅1	K ≥ 1.4	30	—	—	deg.	1
	FSTN			40	—	—	deg.	1
CONTRAST RATIO	STN	K	∅ = 10° θ = 0°	—	5	—	—	1
	FSTN			—	8	—	—	1
RESPONSE TIME	tr (rise)	∅=10° θ = 0°	Ta = -20 °C	—	5538	—	ms	1
			Ta = 25 °C	—	228	—		
			Ta = 70 °C	—	104	—		
	tf (fall)		Ta = -20 °C	—	2316	—		
			Ta = 25 °C	—	174	—		
			Ta = 70 °C	—	85	—		
THE BRIGHTNESS OF BACK-LIGHT	L	IF =360 mA	—	40	—	cd/m ²	1, 2	
			—	75	—		1, 3	
PEAK EMISSION WAVELENGTH	λP	IF =360 mA	—	570	—	nm	1	

NOTE (1) : PLEASE REFER TO :

CUSTOMER ACCEPTANCE STANDARD SPECIFICATIONS.

EU-001A

NOTE (2) : POLARIZER MODE : TRANSFLECTIVE

NOTE (3) : POLARIZER MODE : TRANSMISSIVE

MODEL NO.	VERSION	PAGE
13B30(LED TYPES)	2	6

7. OUTLINE DIMENSION

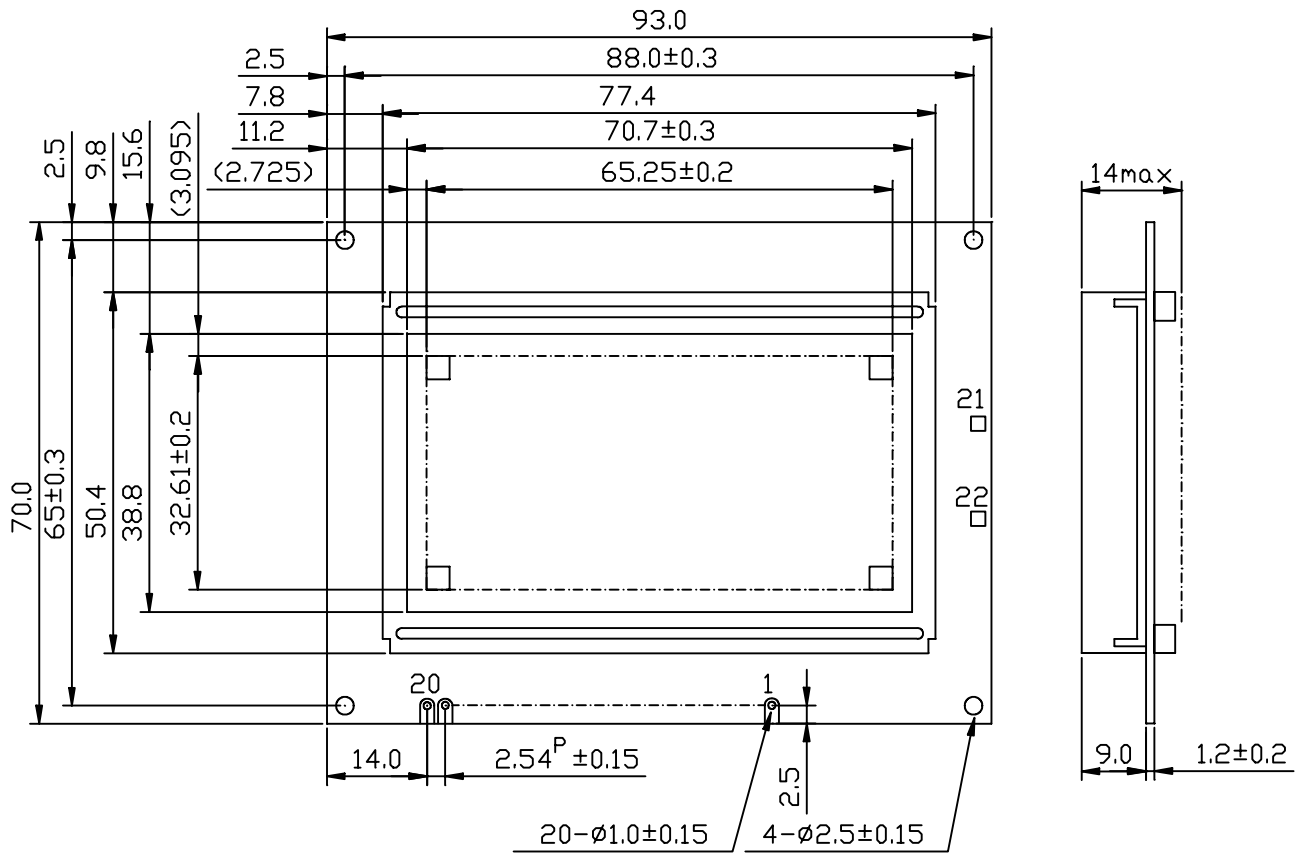

UNIT : mm
 SCALE : NTS
 NOT SPECIFIED TOLERANCE IS ±0.5mm

8. BLOCK DIAGRAM

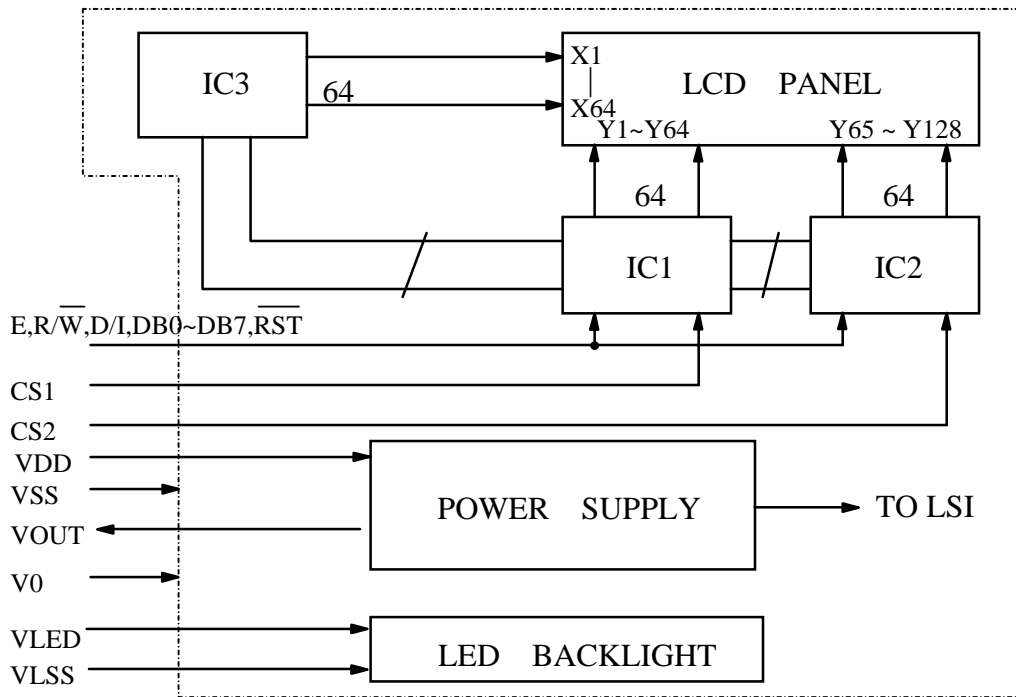

9. DETAIL DRAWING OF DOT MATRIX

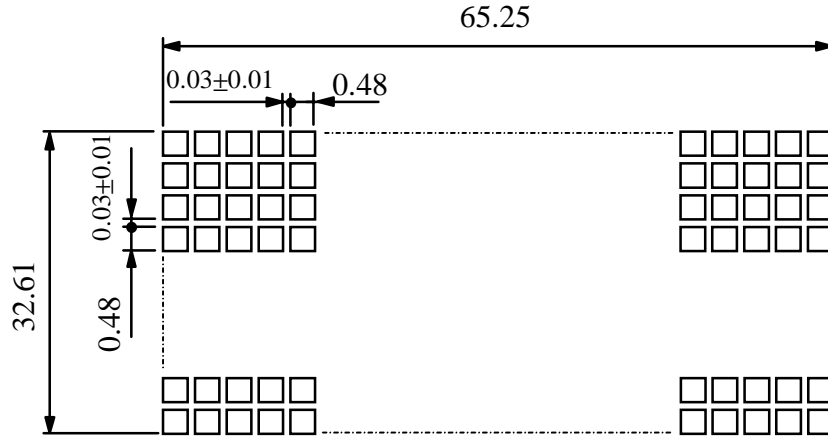

UNIT : mm
 SCALE : NTS
 NOT SPECIFIED TOLERANCE IS ± 0.1

10. INTERFACE SIGNALS

PIN NO	SYMBOL	LEVEL	FUNCTION
1	VSS	—	GROUND
2	VDD	—	POWER SUPPLY FOR LOGIC CIRCUIT
3	VO	—	OPERATING VOLTAGE FOR LCD DRIVING
4	D/I	H/L	H: DATA INPUT L: INSTRUCTION CODE INPUT
5	R/W	H/L	H: DATA READ (LCD MODULE →MPU) L : DATA WRITE (LCD MODULE ←MPU)
6	E	H,H→L	ENABLE SIGNAL
7 14	DB0 DB7	H/L	DATA BUS LINE
15	CS1	H	CHIP SELECTION FOR IC1
16	CS2	H	CHIP SELECTION FOR IC2
17	RST	L	RESET
18	VOUT	—	POWER SUPPLY FOR LCD DRIVING
19	VLED	—	POWER SUPPLY FOR LED BACKLIGHT
20	VLSS	—	POWER SUPPLY FOR LED BACKLIGHT

1 1 . POWER SUPPLY

1 1 . 1 POWER SUPPLY FOR LCM

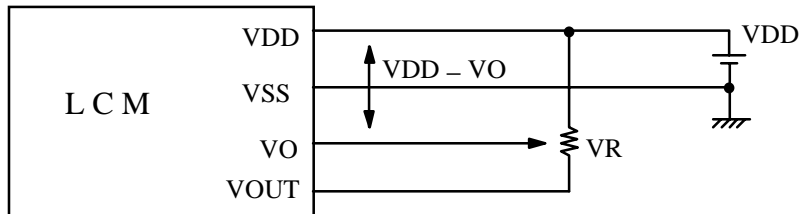

VDD - VO : LCD DRIVING VOLTAGE
 VR : 10K ~ 20KΩ

1 1 . 2 POWER SUPPLY FOR LED BACK - LIGHT

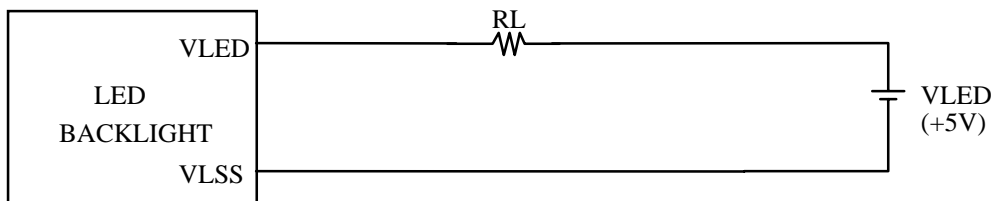

RECOMMENDED RESISTOR $R_L = 2.2 \sim 4.4\Omega, 1/2\text{WATT}$ (CONTROLLED BY USER)
 * THE BRIGHTNESS WOULD BE ALTERED SUBJECT TO DIFFERENT VALUES OF R_L

1 1 . 3 TIMING OF POWER SUPPLY AND INTERFACE SIGNAL

