

EXAMINED BY :  <i>Tony Chen</i>	<p style="text-align: center;"><b>MITSUTECH</b></p> <p style="text-align: center;">INTERNATIONAL CORPORATION</p>	FILE NO . CAS-10098
APPROVED BY:  <i>David Chang</i>		ISSUE : NOV.10,1999
		TOTAL PAGE : 8
		VERSION : 2

CUSTOMER	ACCEPTANCE	SPECIFICATIONS
----------	------------	----------------

MODEL NO. :

13D00(REFLECTIVE TYPES)

FOR MESSRS :

\_\_\_\_\_

CUSTOMER'S APPROVAL

DATE : \_\_\_\_\_

BY : \_\_\_\_\_



MODEL NO . 13D00 (REFLECTIVE TYPES)	VERSION 2
--	--------------

Polarizer Mode	Backlight	Code value
Reflective	—	R

E	W	1	3	D	0	0	G	R
---	---	---	---	---	---	---	---	---

LCD type + LCD color	Code Value
STN + Gray	G
FSTN + White	F

TABLE OF CONTENTS

NO.	ITEM	PAGE
=====		
1.	GENERAL SPECIFICATIONS -----	1
2.	MECHANICAL SPECIFICATIONS -----	1
3.	ABSOLUTE MAXIMUM RATINGS -----	2
4.	ELECTRICAL CHARACTERISTICS -----	3
5.	OPTICAL CHARACTERISTICS -----	4
6.	OUTLINE DIMENSION -----	5
7.	BLOCK DIAGRAM -----	6
8.	DETAIL DRAWING OF DOT MATRIX -----	6
9.	INTERFACE SIGNALS -----	7
10.	POWER SUPPLY -----	8

MODEL NO .	VERSION	PAGE
13D00(REFLECTIVE TYPES)	2	1

1. GENERAL SPECIFICATIONS

1.1 GENERAL SPECIFICATIONS

PLEASE REFER TO :

CUSTOMER ACCEPTANCE STANDARD SPECIFICATIONS :

E U - 0 0 2 A

1.2 APPLICATION NOTES FOR CONTROLLER/DRIVER : T6963C

PLEASE REFER TO :

CUSTOMER ACCEPTANCE STANDARD SPECIFICATIONS :

E U - T 6 9 6 3 C

1.3 THIS INDIVIDUAL SPECIFICATION IS PRIOR TO GENERAL SPECIFICATIONS .

2. MECHANICAL SPECIFICATIONS

- (1) NUMBER OF DOTS ----- 128W \* 128H DOTS
- (2) MODULE SIZE ----- 84.4W \* 100.0H \* 14.0D(max) mm
- (3) VIEWING AREA ----- 62.0W \* 62.0H mm
- (4) ACTIVE AREA ----- 55.01W \* 55.01H mm
- (5) DOT SIZE ----- 0.4W \* 0.4H mm
- (6) DOT PITCH ----- 0.43W \* 0.43H mm
- (7) LCD TYPE \*
- (8) DRIVING METHOD ----- 1 / 128 DUTY MULTIPLEX DRIVE

\* PLEASE REFER TO NUMBERING SYSTEM .

## 3. ABSOLUTE MAXIMUM RATINGS

## 3.1 ELECTRICAL ABSOLUTE MAXIMUM RATINGS .

PARAMETER	SYMBOL	MIN .	MAX .	UNIT	REMARK
POWER SUPPLY FOR LOGIC	VDD — VSS	0	7.0	V	
POWER SUPPLY FOR LCD DRIVING	VDD — VEE	0	22.0	V	
INPUT VOLTAGE	VI	VSS	VDD	V	
STATIC ELECTRICITY	—		100	V	NOTE (1)

NOTE (1) : TEST METHOD AND CONDITIONS :

AFTER CHARGING UP 200 PF CAPACITOR BY STATED VOLTAGE ,  
THE CAPACITOR IS CONNECTED WITH INTERFACE PINS OF THE  
MODULE .

## 3.2 ENVIRONMENTAL ABSOLUTE MAXIMUM RATINGS .

I T E M	OPERATING		STORAGE		REMARK
	MIN .	MAX .	MIN .	MAX .	
AMBIENT TEMPERATURE	-20 °C	70 °C	-30 °C	80 °C	NOTE (2) , (3)
HUMIDITY	—	85 % RH	—	85 % RH	WITHOUT CONDENSATION
VIBRATION	—	2.45 m/s <sup>2</sup> (0.25 G)	—	19.6 m/s <sup>2</sup> (2 G)	10~100 HZ XYZ DIRECTIONS 1 Hr . EACH
SHOCK	—	29.4 m/s <sup>2</sup> (3 G)	—	490.0 m/s <sup>2</sup> (50 G)	10 mSECONDS XYZ DIRECTIONS 1 TIME EACH
CORROSIVE GAS	NOT ACCEPTABLE		NOT ACCEPTABLE		

NOTE (2) : Ta AT -30°C : 48HR MAX .

80°C : 168HR MAX .

NOTE (3) : BACKGROUND COLOR CHANGES SLIGHTLY DEPENDING ON AMBIENT  
TEMPERATURE THIS PHENOMENON IS REVERSIBLE .

4 . ELECTRICAL CHARACTERISTICS

Ta = 25 °C

VDD = 5 . 0 V

VEE-VSS = -12.5V

PARAMETER	SYMBOL	CONDITION	MIN .	TYP .	MAX .	UNIT
POWER SUPPLY VOLTAGE FOR LOGIC	VDD — VSS	—	4.75	5.0	5.25	V
POWER SUPPLY VOLTAGE FOR LCD DRIVE	VEE — VSS	—	- 9.0	- 12.5	- 16.0	V
INPUT VOLTAGE NOTE (1)	VIH	H LEVEL	VDD-2.2	—	VDD	V
	VIL	L LEVEL	0	—	0.8	V
OUTPUT VOLTAGE NOTE (1)	VOH	H LEVEL	VDD-0.3	—	VDD	V
	VOL	L LEVEL	0	—	0.3	V
POWER SUPPLY CURRENT FOR LOGIC NOTE (2)	IDD	VDD-VSS = 5.0 V VDD-VEE = 17.5 V	—	9.0	—	mA
POWER SUPPLY CURRENT FOR DRIVE NOTE (2)	IEE	VDD-VSS = 5.0 V VDD-VEE = 17.5 V	—	3.0	—	mA
RECOMMENDED LCD DRIVING VOLTAGE NOTE (3)	VDD-VEE ∅ = 10° θ = 0°	Ta = - 20 °C	—	17.5	—	V
		Ta = 25 °C	—	17.5	—	
		Ta = 70 °C	—	14.5	—	
CLOCK OSCILLATION FREQUENCY	f osc	—	—	5.0	—	MHZ

NOTE (1): APPLIED TO TERMINALS  $\overline{WR}$ ,  $\overline{RD}$ ,  $\overline{CE}$ ,  $\overline{C/D}$ ,  $\overline{RST}$ , FS, DB0~DB7.

NOTE (2): THE DISPLAY PATTERN IS ALL "OFF" "/" "ON" .

NOTE (3): RECOMMENDED LCD DRIVING VOLTAGE MAY FLUCTUATE ABOUT ± 1.0V BY EACH MODULE .

5. OPTICAL CHARACTERISTICS

Ta = 25 °C

VDD = 5.0 V

VDD-VEE = 17.5V

I T E M		SYMBOL	CONDITION	MIN.	TYP.	MAX.	UNIT	NOTE
VIEWING AREA	STN	∅2 - ∅1	K ≥ 1.4	40	—	—	deg.	1
	FSTN			50	—	—	deg.	1
CONTRAST RATIO	STN	K	∅ = 10° θ = 0°	—	5	—	—	1
	FSTN			5	—	—	—	1
RESPONSE TIME	tr ( rise )	∅=10° θ = 0°	Ta = -20°C	—	2886	—	ms	1
			Ta = 25°C	—	259	—		
			Ta = 70°C	—	156	—		
	tf ( fall )		Ta = -20°C	—	2193	—		
			Ta = 25°C	—	177	—		
			Ta = 70°C	—	84	—		

NOTE (1) : PLEASE REFER TO :  
 CUSTOMER ACCEPTANCE STANDARD SPECIFICATIONS.  
 E U - 0 0 2 A

6. OUTLINE DIMENSION

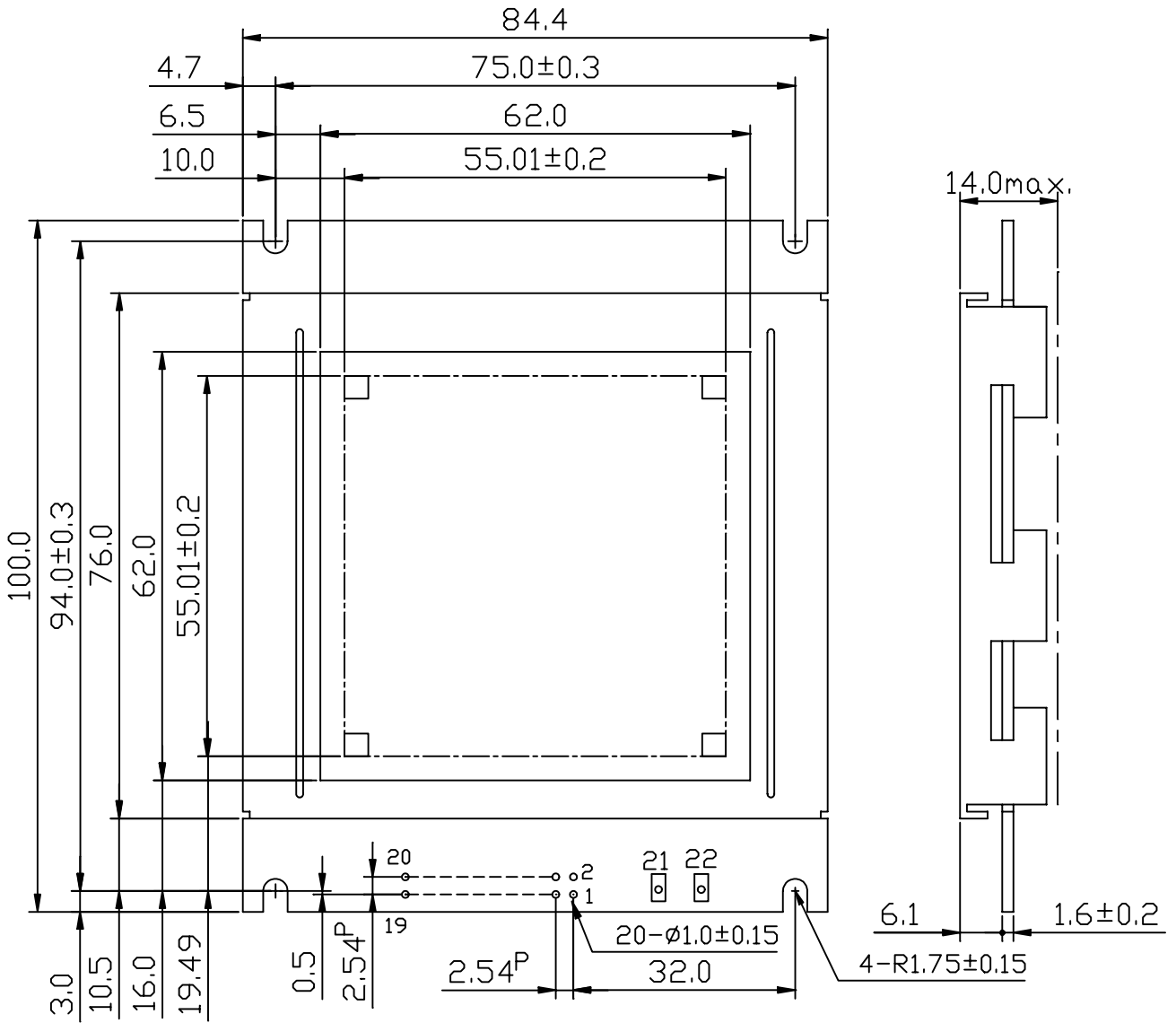

UNIT : mm  
 SCALE : NTS  
 NOT SPECIFIED TOLERANCE IS ± 0.5

7. DETAIL DRAWING OF DOT MATRIX

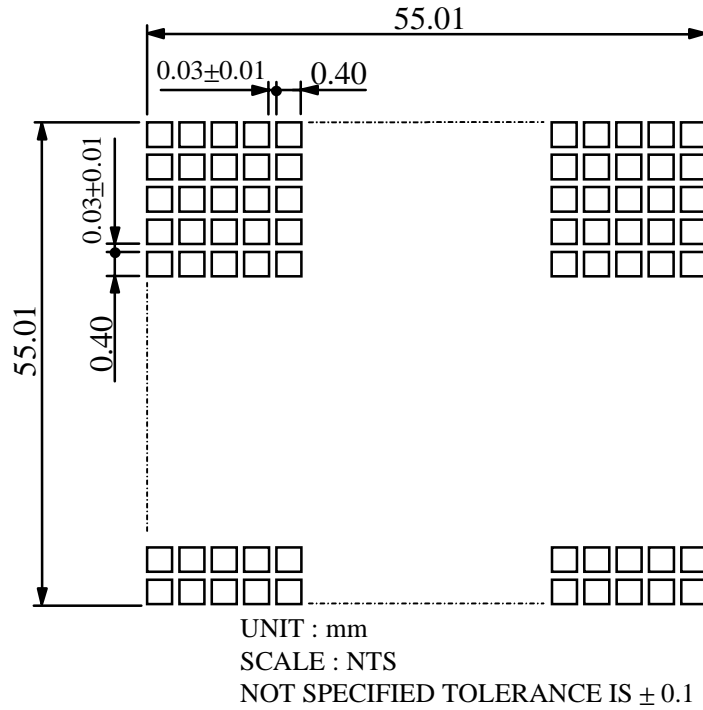

8. BLOCK DIAGRAM

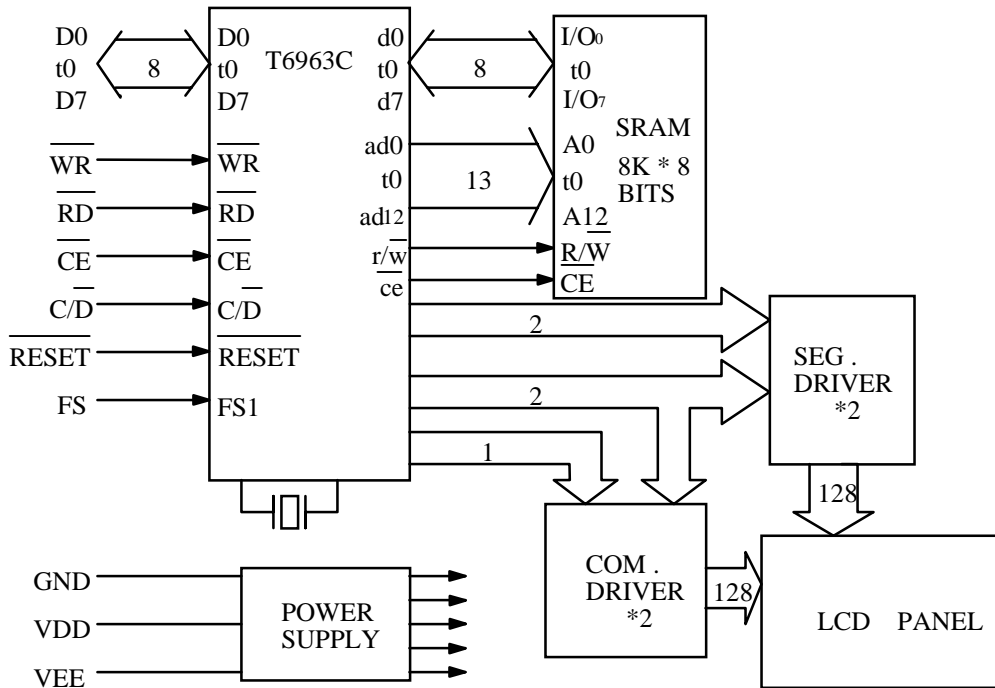

9. INTERFACE SIGNALS

PIN NO .	SIGNAL	FUNCTION
1	FGND	FRAME GROUND ( 0V )
2	GND	GROUND
3	VDD	POWER SUPPLY FOR LOGIC ( +5V )
4	VEE	POWER SUPPLY FOR LCD DRIVE
5	$\overline{\text{WR}}$	DATA WRITE
6	$\overline{\text{RD}}$	DATA READ
7	$\overline{\text{CE}}$	CHIP ENABLE
8	$\overline{\text{C/D}}$	$\overline{\text{WR}} = " L " , \overline{\text{C/D}} = " H " : \text{COMMAND WRITE}$ $\overline{\text{C/D}} = " L " : \text{DATA WRITE}$ $\overline{\text{RD}} = " L " , \overline{\text{C/D}} = " H " : \text{STATUS READ}$ $\overline{\text{C/D}} = " L " : \text{DATA READ}$
9	NC	—————
10	$\overline{\text{RESET}}$	CONTROLLER RESET
11~18	D0~D7	DATA INPUT/OUTPUT
19	FS	FONT SELECT : CONNECT TO VDD : 6*8 PIXEL/FONT CONNECT TO GND : 8*8 PIXEL/FONT
20	NC	—————

10. POWER SUPPLY

10.1 POWER SUPPLY FOR LCM

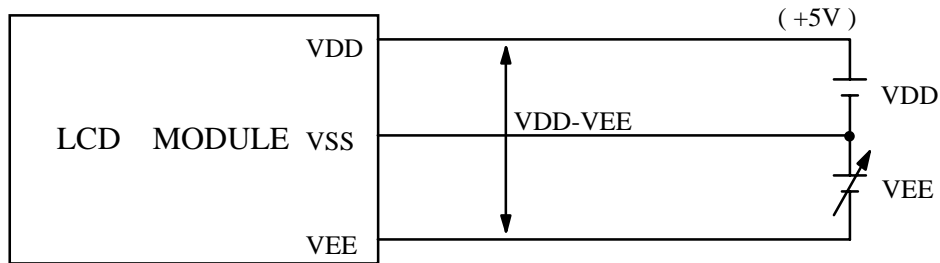

VDD-VEE : LCD DRIVING VOLTAGE

10.2 TIMING OF POWER SUPPLY AND INTERFACE SIGNAL

