

EXAMINED BY : <i>Tony Chen</i>	MITSUTECH INTERNATIONAL CORPORATION	FILE NO . CAS-10082
APPROVED BY:		ISSUE : NOV.08,1999
<i>David Chang</i>		TOTAL PAGE : 8
		VERSION : 2

CUSTOMER	ACCEPTANCE	SPECIFICATIONS
----------	------------	----------------

MODEL NO. :

162D0(LED TYPES)

FOR MESSRS :

CUSTOMER'S APPROVAL

DATE : _____

BY : _____

MITSUTECH INT'L CORP.

MODEL NO.

162D0(LED TYPES)

VERSION

2

RECORDS OF REVISION

DOC . FIRST ISSUE

APR.03,1998

DATE	REVISED PAGE NO.	SUMMARY
NOV.08,1999	1~4	THE ENTIRE PAGES REVISED

NUMBERING SYSTEM

Module type: D: TN Character Modules
 W: Wide Temp. Modules

Polarizer Mode	Backlight	Code value
Transflective	LED	L
Transmissive	LED	M

Backlight Color	Code Value
Yellow-Green	Y

E W 16 2 D0 G L Y *

Viewing direction
 NIL.: 6 o'clock
 U: 12 o'clock

LCD type + LCD color	Code Value
TN + Gray	T
STN + Yellow-Green	Y
STN + Gray	G
STN + Blue	B

* : AVAILABLE ONLY FOR TN TYPE

TABLE OF CONTENTS

NO.	ITEM	PAGE
1.	GENERAL SPECIFICATIONS -----	1
2.	MECHANICAL SPECIFICATIONS -----	1
3.	ABSOLUTE MAXIMUM RATINGS -----	2
4.	ELECTRICAL CHARACTERISTICS -----	3
5.	OPTICAL CHARACTERISTICS -----	4
6.	OUTLINE DIMENSION -----	5
7.	DETAIL DRAWING OF DOT MATRIX -----	6
8.	BLOCK DIAGRAM -----	6
9.	INTERFACE SIGNALS -----	7
10.	POWER SUPPLY -----	8
11.	DISPLAY DATA RAM ADDRESS -----	8

1. GENERAL SPECIFICATIONS

1.1 GENERAL SPECIFICATIONS

PLEASE REFER TO :

CUSTOMER ACCEPTANCE STANDARD SPECIFICATIONS :

E U - 0 0 2 A

1.2 APPLICATION NOTES FOR CONTROLLER / DRIVER :

PLEASE REFER TO :

CUSTOMER ACCEPTANCE STANDARD SPECIFICATIONS :

E U - K S 0 0 6 6

1.3 THIS INDIVIDUAL SPECIFICATIONS IS PRIOR TO GENERAL SPECIFICATIONS .

2. MECHANICAL SPECIFICATIONS

- (1) NUMBER OF CHARACTER ----- 16 CH * 2 LINES
- (2) MODULE SIZE ----- 85.0W * 30.0H * 14.0D (max.) mm
- (3) EFFECTIVE AREA ----- 64.5W * 13.8H mm
- (4) CHARACTER FONT ----- 5 * 7 DOTS + CURSOR
- (5) CHARACTER SIZE ----- 2.95W * 4.35H mm
- (6) CHARACTER PITCH ----- 3.65W * 5.05H mm
- (7) DOT SIZE ----- 0.55W * 0.50H mm
- (8) DOT PITCH ----- 0.60W * 0.55H mm
- (9) LCD TYPE *
- (10) DRIVING METHOD ----- 1/16 DUTY MULTIPLEX DRIVE
- (11) VIEWING DIRECTION *
- (12) BACK-LIGHT ----- LED, COLOR : YELLOW-GREEN

* PLEASE REFER TO NUMBERING SYSTEM .

3. ABSOLUTE MAXIMUM RATINGS

3.1 ELECTRICAL ABSOLUTE MAXIMUM RATINGS . (AT Ta = 25 °C)

PARAMETER	SYMBOL	MIN .	MAX .	UNIT	REMARK
POWER SUPPLY FOR LOGIC	VDD - VSS	0	7.0	V	
POWER SUPPLY FOR LCD DRIVE	VDD - V0	0	13.0	V	
INPUT VOLTAGE	VI	VSS	VDD	V	
STATIC ELECTRICITY	—	—	100	V	NOTE (1)
LED POWER DISSIPATION	PD	—	1.3	W	
LED FORWARD CURRENT	IF	—	260	mA	
LED REVERSE VOLTAGE	VR	—	8	V	

NOTE (1) : TEST METHOD AND CONDITIONS :
 AFTER CHARGING UP 200 PF CAPACITOR BY STATED VOLTAGE ,
 THE CAPACITOR IS CONNECTED WITH INTERFACE PINS OF THE
 MODULE .

3.2 ENVIRONMENTAL ABSOLUTE MAXIMUM RATINGS .

I T E M		OPERATING		STORAGE		REMARK
		MIN .	MAX .	MIN .	MAX .	
AMBIENT TEMPERATURE	ED	0 °C	50 °C	-20 °C	70 °C	NOTE (2), (3)
	EW	-20 °C	70 °C	-30 °C	80 °C	
HUMIDITY		—	90 % RH	—	90 % RH	WITHOUT CONDENSATION
VIBRATION		—	4.9 m/s ² (0.5 G)	—	19.6 m/s ² (2 G)	
SHOCK		—	29.4 m/s ² (3 G)	—	490.0 m/s ² (50 G)	XYZ DIRECTIONS
CORROSIVE GAS		NOT ACCEPTABLE		NOT ACCEPTABLE		

NOTE (2) : Ta AT -20°C (-30°C FOR EW) : 48HR MAX .

70°C (80°C FOR EW) : 168HR MAX .

NOTE (3) : BACKGROUND COLOR CHANGES SLIGHTLY DEPENDING ON AMBIENT TEMPERATURE THIS PHENOMENON IS REVERSIBLE .

4. ELECTRICAL CHARACTERISTICS

PARAMETER	SYMBOL	CONDITION	Ta = 25°C			UNIT	
			MIN .	TYP .	MAX .		
H LEVEL INPUT VOLTAGE	VIH	—	2.2	—	—	V	
L LEVEL INPUT VOLTAGE	VIL	—	—	—	0.6	V	
H LEVEL OUTPUT VOLTAGE	VOH	-IOH = 0.2 mA	2.4	—	—	V	
L LEVEL OUTPUT VOLTAGE	VOL	IOL = 1.2 mA	—	—	0.4	V	
POWER SUPPLY CURRENT (LOGIC)	IDD	VDD = 5.0 V	—	1.0	3.0	mA	
RECOMMENDED LCD DRIVING VOLTAGE	VDD - VO ∅ = 25°, θ = ** DUTY= 1/16	ED	Ta = 0 °C	—	4.2	—	V
			Ta = 25 °C	—	3.8	—	V
			Ta = 50 °C	—	3.4	—	V
	VDD - VO ∅ = 10°, θ = 0° DUTY= 1/16	EW	Ta = - 20 °C	—	4.4	—	V
			Ta = 25 °C	—	4.4	—	V
			Ta = 70 °C	—	4.4	—	V
CLOCK OSCILLATION FREQUENCY	FOSC	Ta = 25 °C	—	270	—	KHZ	
LED FORWARD VOLTAGE	VF	IF = 130 mA	—	4.2	4.6	V	
LED FORWARD CURRENT	IF	—	—	130	—	mA	
LED REVERSE CURRENT	IR	VR = 8V	—	—	0.2	mA	

** θ = 0° WHEN VIEWING DIRECTION IS 6 O'CLOCK
θ = 180° WHEN VIEWING DIRECTION IS 12 O'CLOCK

5. OPTICAL CHARACTERISTICS .

Ta = 25 °C

VDD = 5.0 V

I T E M		SYMBOL	CONDITION		MIN .	TYP .	MAX .	UNIT	NOTE	
VIEWING AREA	ED	∅ 2 - ∅ 1	K ≥ 1.4		20	—	—	deg.	1	
	EW				30	—	—	deg.	1	
CONTRAST RATIO	ED	K	∅ = 25°, θ = **		—	3	—	—	1	
	EW		∅ = 10°, θ = 0°		5	—	—	—	1	
RESPONSE TIME	ED	tr (rise)	∅ = 25°	Ta = 25°C	—	150	250	ms	1	
				Ta = 25°C	—	100	150			
	EW	tr (rise)	∅ = 10°	θ = 0°	Ta = -20°C	—	5538			—
					Ta = 25°C	—	228			—
		Ta = 70°C			—	104	—			
		tf (fall)			Ta = -20°C	—	2316			—
					Ta = 25°C	—	174			—
					Ta = 70°C	—	85			—
THE BRIGHTNESS OF BACK-LIGHT	L		IF = 130 mA		—	31	—	cd/m ²	1, 2	
					—	67	—		1, 3	
PEAK EMISSION WAVELENGTH	λ P		IF = 130 mA		—	572	—	nm	1	

** θ = 0° WHEN VIEWING DIRECTION IS 6 O'CLOCK

θ = 180° WHEN VIEWING DIRECTION IS 12 O'CLOCK

NOTE (1): PLEASE REFER TO :

CUSTOMER ACCEPTANCE STANDARD SPECIFICATION : EU-002A

NOTE (2): POLARIZER MODE : TRANSFLECTIVE

NOTE (3): POLARIZER MODE : TRANSMISSIVE

MODEL NO .	VERSION	PAGE
162D0(LED TYPES)	2	5

6. OUTLINE DIMENSION

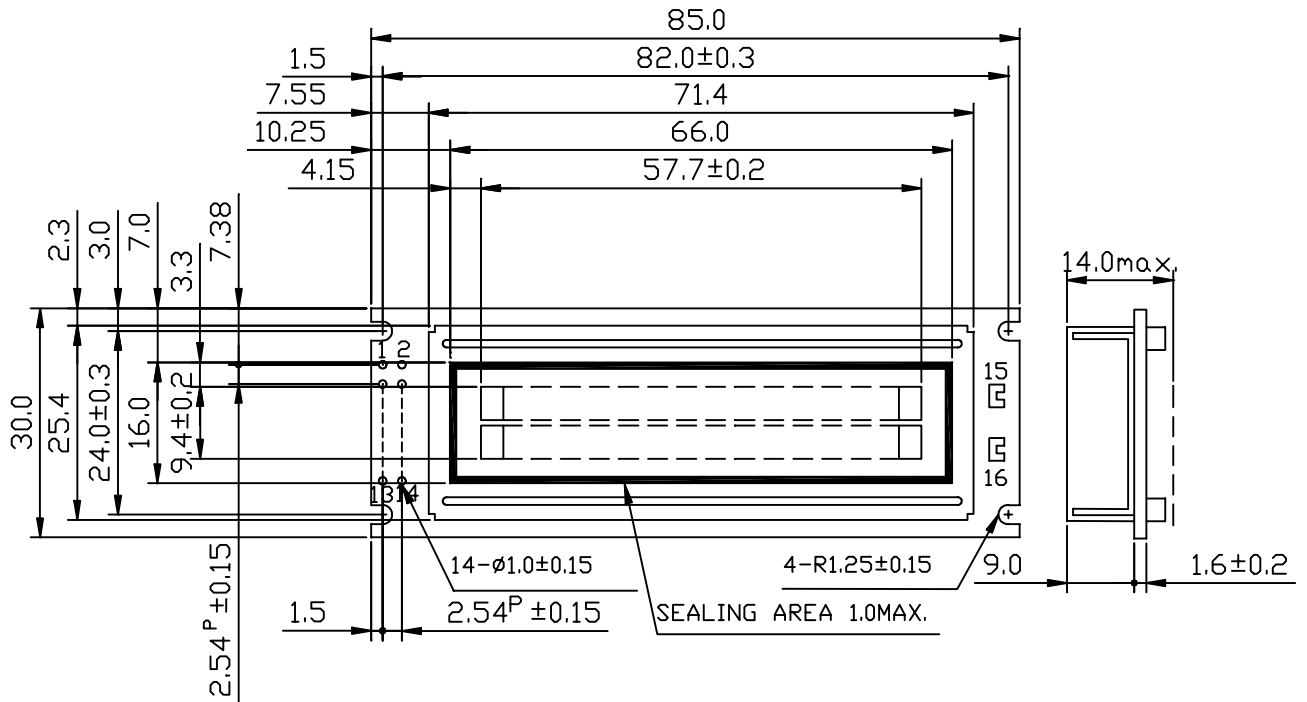

UNIT : mm
 SCALE : NTS
 NOT SPECIFIED TOLERANCE IS ±0.5mm

7. DETAIL DRAWING OF DOT MATRIX

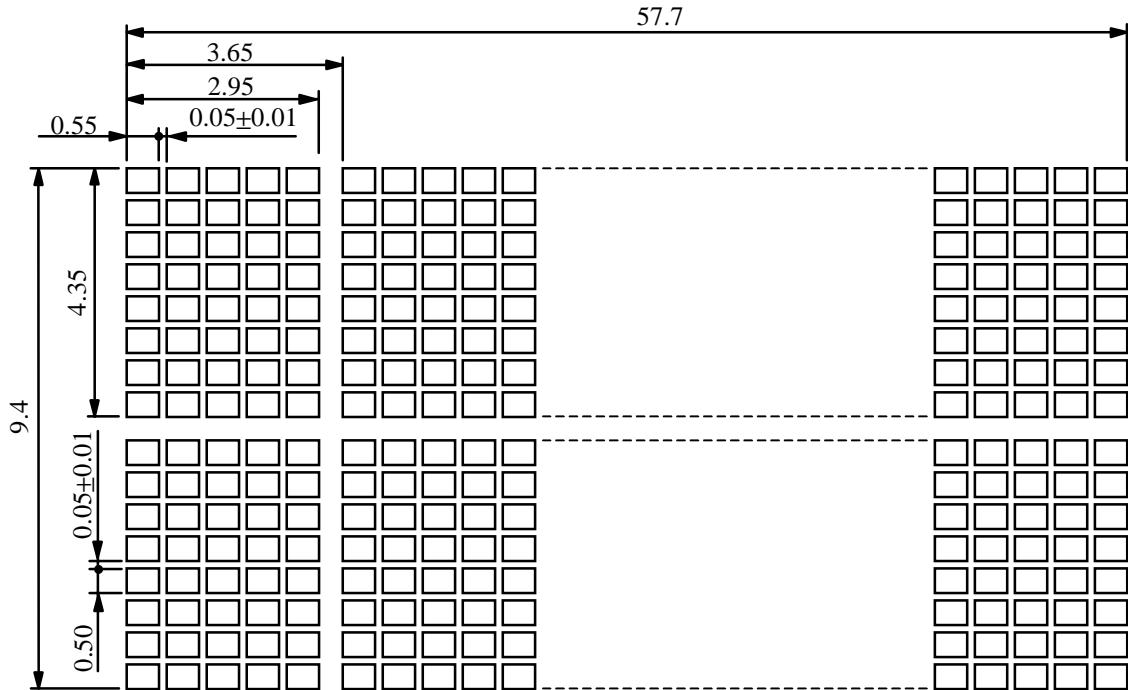

UNIT : mm
 SCALE : NTS
 NOT SPECIFIED TOLERANCE IS ±0.1

8. BLOCK DIAGRAM

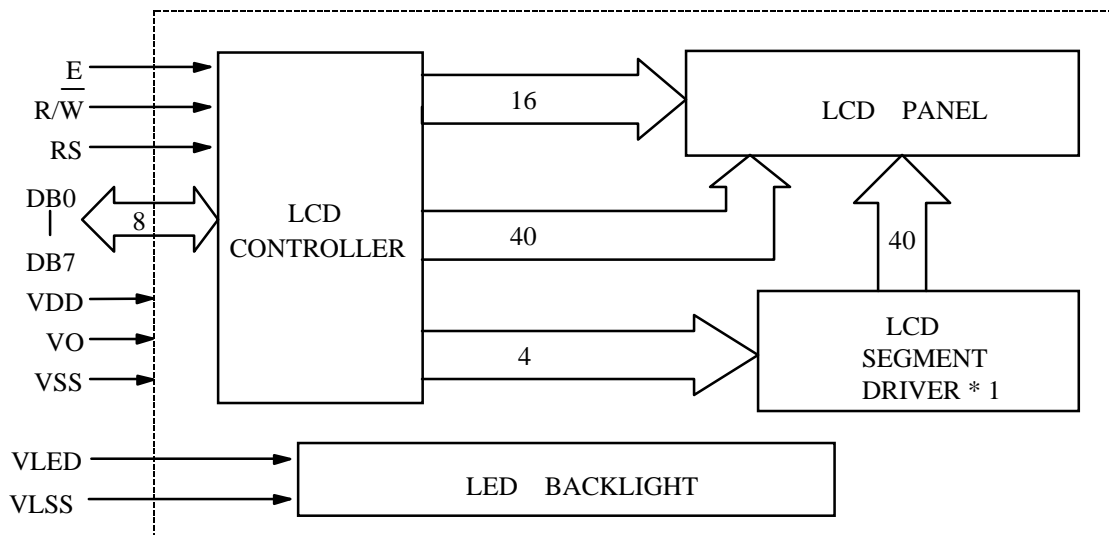

9. INTERFACE SIGNALS

PIN NO.	SYMBOL	DESCRIPTION	FUNCTION
1 8	DB7 DB0	DATA INPUT/OUTPUT LINES	4 BIT/ 8 BIT SELECTABLE 4 BIT:DB4-DB7 8 BIT:DB0-DB7
9	E	ENABLE INPUT	
10	$\overline{R/W}$	READ/WRITE SELECTION	$\overline{R/W} = 0$: REGISTER WRITE $\overline{R/W} = 1$: REGISTER READ
11	RS	INSTRUCTION/DATA REGISTER SELECTION	RS = 0 : INSTRUCTION REGISTER RS = 1: DATA REGISTER
12	VO	LCD CONTRAST ADJUSTMENT	
13	VSS	GROUND	0V (GND)
14	VDD	POWER SUPPLY FOR LOGIC CIRCUIT	+5V
15	VLED	POWER SUPPLY FOR LED LED BACKLIGHT (ANODE)	
16	VLSS	POWER SUPPLY FOR LED LED BACKLIGHT (CATHODE)	0V (GND)

10. POWER SUPPLY

10.1 POWER SUPPLY FOR LCD MODULE

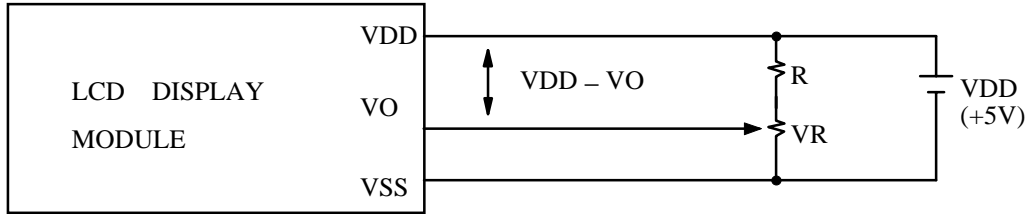

VDD - VO : LCD DRIVING VOLTAGE

VR : 10KΩ ~ 20KΩ

RECOMMENDED RESISTOR R : $VDD - VO \geq 1.5 V$

10.2 POWER SUPPLY FOR LED BACKLIGHT

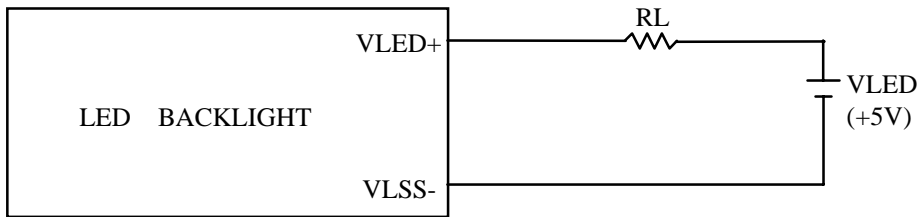

RECOMMENDED RESISTOR RL : 6~3Ω, 1/4 WATT (CONTROLLED BY USER)

* THE BRIGHTNESS WOULD BE ALTERED SUBJECT TO DIFFERENT VALUES OF RL

11. DISPLAY DATA RAM ADDREASS

CHARACTER	1	2	3	4	5	6	7	8	9	10	11	12	13	14	15	16
LINE 1	80	81	82	83	84	85	86	87	88	89	8A	8B	8C	8D	8E	8F
LINE 2	C0	C1	C2	C3	C4	C5	C6	C7	C8	C9	CA	CB	CC	CD	CE	CF