

EXAMINED BY:  <i>Jony Chen</i>	<b>MITSU</b> <b>TECH</b>  INTERNATIONAL CORPORATION	FILE NO . CAS-10149
APPROVED BY:  <i>David Chang</i>		ISSUE : NOV.09,1999
		TOTAL PAGE : 7
		VERSION : 2

CUSTOMER
ACCEPTANCE
SPECIFICATIONS

MODEL NO. :

162G0(REFLECTIVE TYPES)

FOR MESSRS :

\_\_\_\_\_

CUSTOMER'S APPROVAL

DATE :

\_\_\_\_\_

BY :

\_\_\_\_\_



NUMBERING SYSTEM

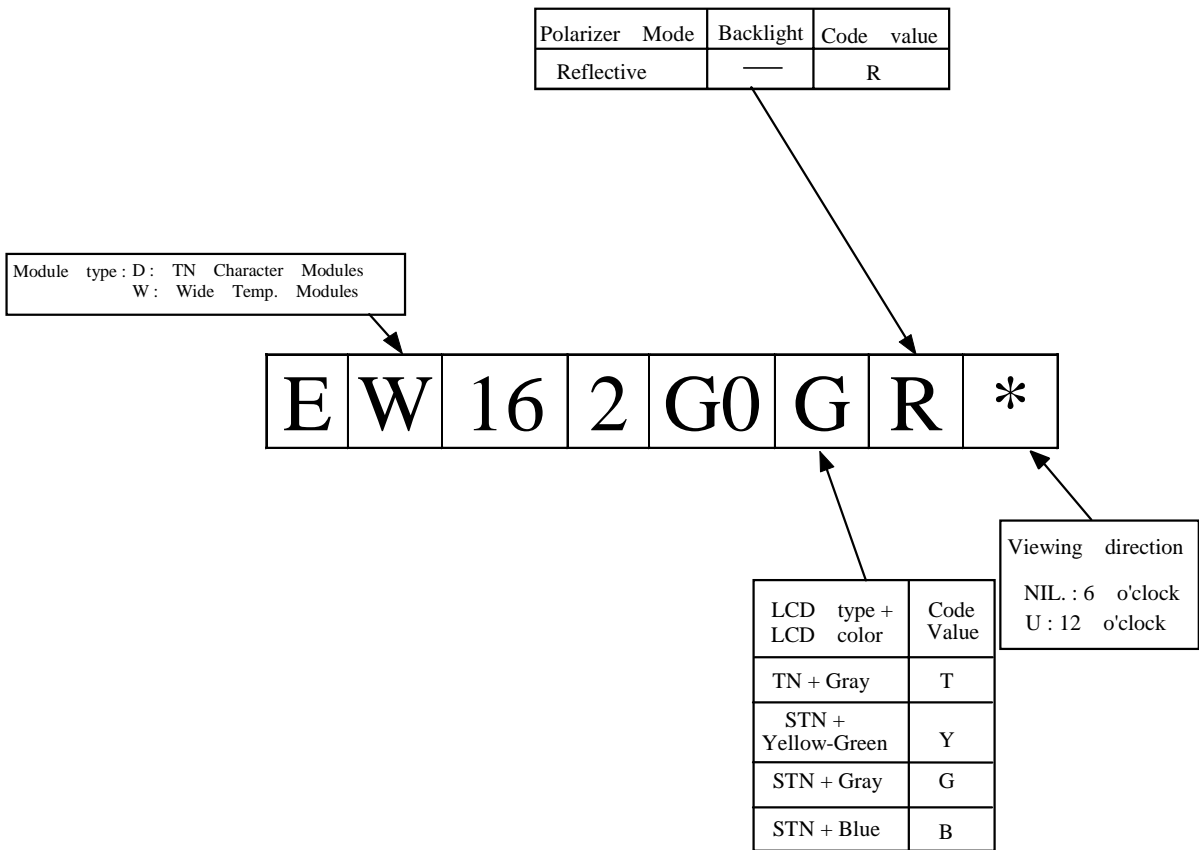

\* : AVAILABLE ONLY FOR TN TYPE

TABLE OF CONTENTS

NO.	ITEM	PAGE
=====		
1.	GENERAL SPECIFICATIONS -----	1
2.	MECHANICAL SPECIFICATIONS -----	1
3.	ABSOLUTE MAXIMUM RATINGS -----	2
4.	ELECTRICAL CHARACTERISTICS -----	3
5.	OPTICAL CHARACTERISTICS -----	3
6.	OUTLINE DIMENSION -----	4
7.	DETAIL DRAWING OF DOT MATRIX -----	5
8.	BLOCK DIAGRAM -----	5
9.	INTERFACE SIGNALS -----	6
10.	POWER SUPPLY -----	7
11.	DISPLAY DATA RAM ADDRESS -----	7

## 1. GENERAL SPECIFICATIONS

### 1.1 GENERAL SPECIFICATIONS

PLEASE REFER TO :

CUSTOMER ACCEPTANCE STANDARD SPECIFICATIONS :

E U - 0 0 2 A

### 1.2 APPLICATION NOTES FOR CONTROLLER / DRIVER :

PLEASE REFER TO :

CUSTOMER ACCEPTANCE STANDARD SPECIFICATIONS :

E U - K S 0 0 6 6

### 1.3 THIS INDIVIDUAL SPECIFICATIONS IS PRIOR TO GENERAL SPECIFICATIONS .

## 2. MECHANICAL SPECIFICATIONS

- (1) NUMBER OF CHARACTER ----- 16 CH \* 2 LINES
- (2) MODULE SIZE ----- 80.0W \* 36.0H \* 10.0D (max.) mm
- (3) EFFECTIVE AREA ----- 64.5W \* 13.8H mm
- (4) CHARACTER FONT ----- 5 \* 7 DOTS + CURSOR
- (5) CHARACTER SIZE ----- 2.96W \* 5.56H mm
- (6) CHARACTER PITCH ----- 3.55W \* 5.94H mm
- (7) DOT SIZE ----- 0.56W \* 0.66H mm
- (8) DOT PITCH ----- 0.60W \* 0.70H mm
- (9) LCD TYPE \*
- (10) DRIVING METHOD ----- 1 / 16 DUTY MULTIPLEX DRIVE
- (11) VIEWING DIRECTION \*

\* PLEASE REFER TO NUMBERING SYSTEM

### 3. ABSOLUTE MAXIMUM RATINGS

#### 3.1 ELECTRICAL ABSOLUTE MAXIMUM RATINGS . ( AT Ta = 25 °C )

PARAMETER	SYMBOL	MIN .	MAX .	UNIT	REMARK
POWER SUPPLY FOR LOGIC	VDD – VSS	0	7.0	V	
POWER SUPPLY FOR LCD DRIVE	VDD – VO	0	13.0	V	
INPUT VOLTAGE	VI	VSS	VDD	V	
STATIC ELECTRICITY	—	—	100	V	NOTE (1)

NOTE (1) : TEST METHOD AND CONDITIONS :  
 AFTER CHARGING UP 200 PF CAPACITOR BY STATED VOLTAGE ,  
 THE CAPACITOR IS CONNECTED WITH INTERFACE PINS OF THE  
 MODULE .

#### 3.2 ENVIRONMENTAL ABSOLUTE MAXIMUM RATINGS .

I T E M		OPERATING		STORAGE		REMARK
		MIN .	MAX .	MIN .	MAX .	
AMBIENT TEMPERATURE	ED	0 °C	50 °C	-20 °C	70 °C	NOTE (2), (3)
	EW	-20 °C	70 °C	-30 °C	80 °C	
HUMIDITY		—	90 % RH	—	90 % RH	WITHOUT CONDENSATION
VIBRATION		—	4.9 m/s <sup>2</sup> (0.5 G)	—	19.6 m/s <sup>2</sup> (2 G)	
SHOCK		—	29.4 m/s <sup>2</sup> (3 G)	—	490.0 m/s <sup>2</sup> (50 G)	XYZ DIRECTIONS
CORROSIVE GAS		NOT ACCEPTABLE		NOT ACCEPTABLE		

NOTE (2) : Ta AT -20°C (-30°C FOR EW) : 48HR MAX .

70°C ( 80°C FOR EW) : 168HR MAX .

NOTE (3) : BACKGROUND COLOR CHANGES SLIGHTLY DEPENDING ON AMBIENT TEMPERATURE THIS PHENOMENON IS REVERSIBLE .

## 4. ELECTRICAL CHARACTERISTICS

Ta = 25°C

VDD = 5.0 ± 0.25 V

PARAMETER	SYMBOL	CONDITION	MIN.	TYP.	MAX.	UNIT	
H LEVEL INPUT VOLTAGE	VIH	—	2.2	—	—	V	
L LEVEL INPUT VOLTAGE	VIL	—	—	—	0.6	V	
H LEVEL OUTPUT VOLTAGE	VOH	-IOH = 0.2 mA	2.4	—	—	V	
L LEVEL OUTPUT VOLTAGE	VOL	IOL = 1.2 mA	—	—	0.4	V	
POWER SUPPLY CURRENT (LOGIC)	IDD	VDD = 5.0 V	—	1.0	3.0	mA	
RECOMMENDED LCD DRIVING VOLTAGE	VDD - VO ∅ = 25°, θ = ** DUTY = 1/16	ED	Ta = 0 °C	—	4.2	—	V
			Ta = 25 °C	—	3.8	—	V
			Ta = 50 °C	—	3.4	—	V
	VDD - VO ∅ = 10°, θ = 0° DUTY = 1/16	EW	Ta = -20 °C	—	4.4	—	V
			Ta = 25 °C	—	4.4	—	V
			Ta = 70 °C	—	4.4	—	V
CLOCK OSCILLATION FREQUENCY	FOSC	Ta = 25 °C	—	270	—	KHZ	

## 5. OPTICAL CHARACTERISTICS .

Ta = 25 °C

VDD = 5.0 V

I T E M		SYMBOL	CONDITION	MIN.	TYP.	MAX.	UNIT	NOTE	
VIEWING AREA	ED	∅ 2 - ∅ 1	K ≥ 1.4	20	—	—	deg.	1	
	EW			30	—	—	deg.	1	
CONTRAST RATIO	ED	K	∅ = 25°, θ = **	—	3	—	—	1	
	EW		∅ = 10°, θ = 0°	5	—	—	—	1	
RESPONSE TIME	ED	tr ( rise )	∅ = 25° θ = **	Ta = 25°C	—	150	250	ms	1
				Ta = 25°C	—	100	150		
	EW	tr ( rise )	∅ = 10° θ = 0°	Ta = -20°C	—	5538	—		
				Ta = 25°C	—	228	—		
				Ta = 70°C	—	104	—		
		tf ( fall )		Ta = -20°C	—	2316	—		
				Ta = 25°C	—	174	—		
				Ta = 70°C	—	85	—		

\*\* θ = 0° WHEN VIEWING DIRECTION IS 6 O'CLOCK

θ = 180° WHEN VIEWING DIRECTION IS 12 O'CLOCK

NOTE (1): PLEASE REFER TO :

CUSTOMER ACCEPTANCE STANDARD SPECIFICATION : EU-002A

6. OUTLINE DIMENSION

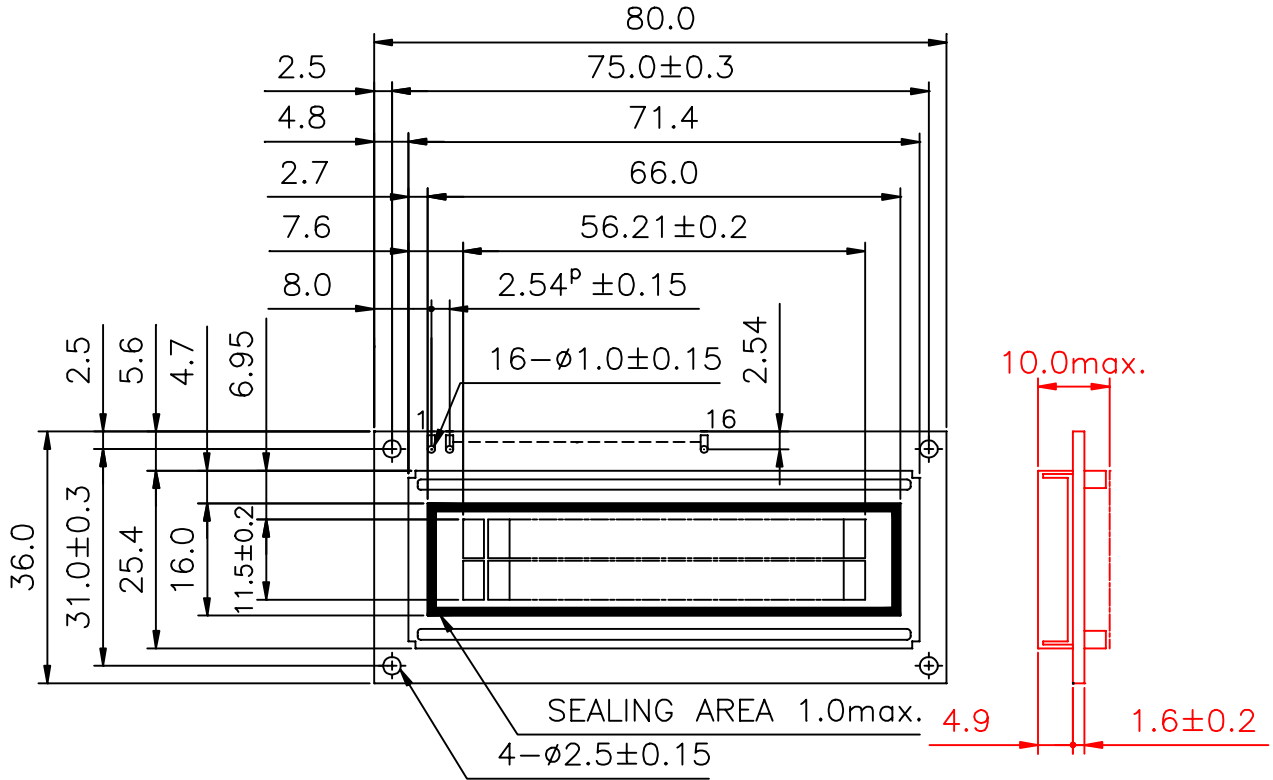

UNIT : mm  
SCALE : NTS  
NOT SPECIFIED TOLERANCE IS ±0.5

7. DETAIL DRAWING OF DOT MATRIX

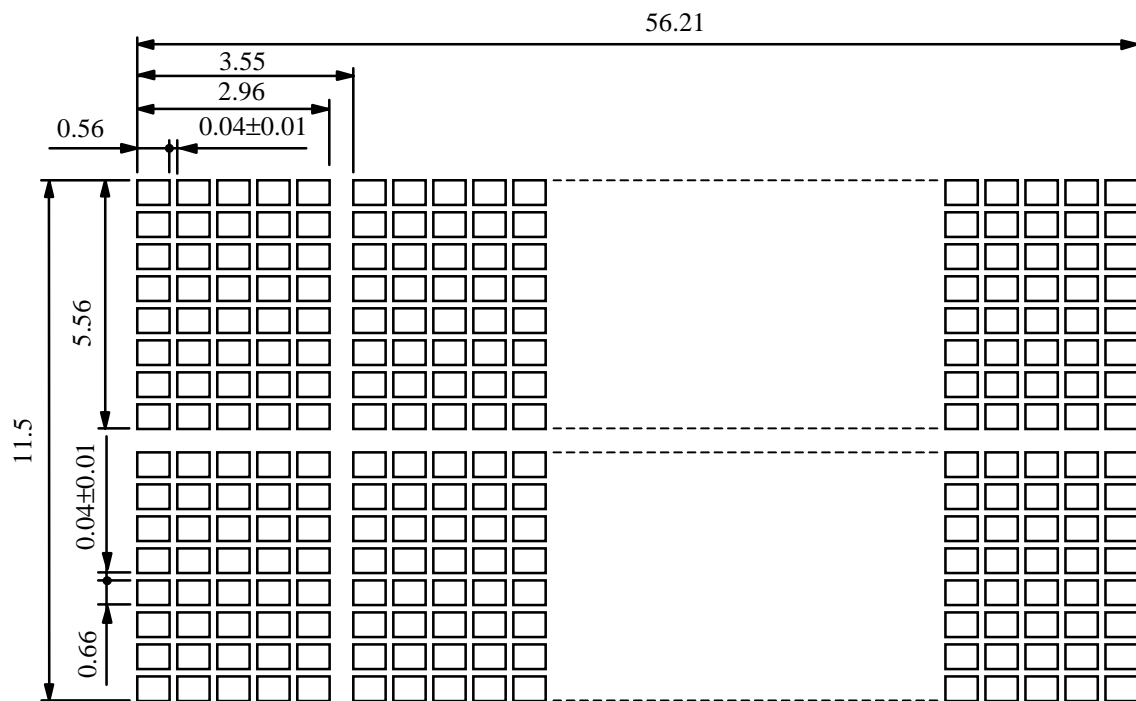

UNIT : mm  
 SCALE : NTS  
 NOT SPECIFIED TOLERANCE IS ± 0.1

8. BLOCK DIAGRAM

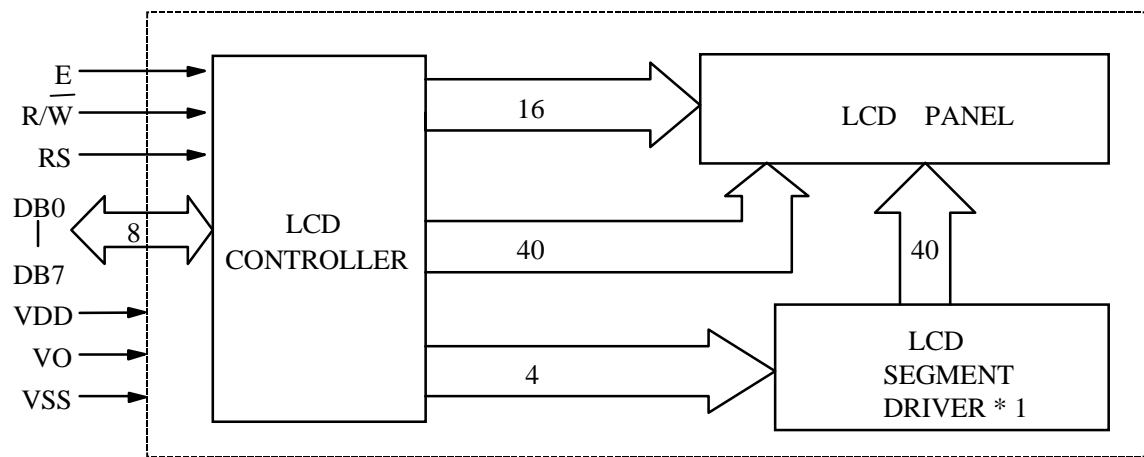

## 9. INTERFACE SIGNALS

PIN NO.	SYMBOL	DESCRIPTION	FUNCTION
1	VSS	GROUND	0V (GND)
2	VDD	POWER SUPPLY FOR LOGIC CIRCUIT	+5V
3	VO	LCD CONTRAST ADJUSTMENT	
4	RS	INSTRUCTION/DATA REGISTER SELECTION	RS = 0 : INSTRUCTION REGISTER RS = 1 : DATA REGISTER
5	$\overline{R/W}$	READ/WRITE SELECTION	$\overline{R/W}$ = 0 : REGISTER WRITE $\overline{R/W}$ = 1 : REGISTER READ
6	E	ENABLE INPUT	
7	DB0	DATA INPUT/OUTPUT LINES	4 BIT/8BIT SELECTABLE  4 BIT : DB4 - DB7 8 BIT : DB0 - DB7
8	DB1		
9	DB2		
10	DB3		
11	DB4		
12	DB5		
13	DB6		
14	DB7		

1 0 . POWER SUPPLY

1 0 . 1 POWER SUPPLY FOR LCD MODULE

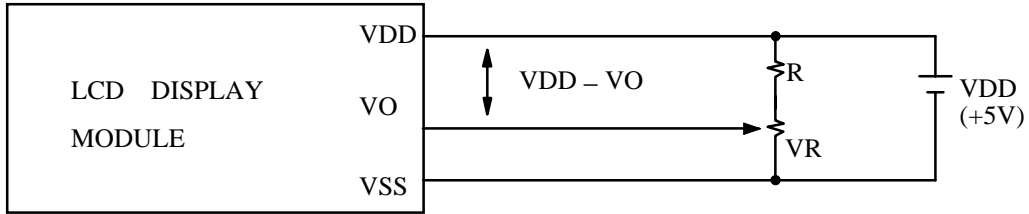

VDD - VO : LCD DRIVING VOLTAGE

VR : 10KΩ ~ 20KΩ

RECOMMENDED RESISTOR R :  $VDD - VO \geq 1.5 V$

1 1 . DISPLAY DATA RAM ADDRESS

CHARACTER	1	2	3	4	5	6	7	8	9	10	11	12	13	14	15	16
LINE 1	80	81	82	83	84	85	86	87	88	89	8A	8B	8C	8D	8E	8F
LINE 2	C0	C1	C2	C3	C4	C5	C6	C7	C8	C9	CA	CB	CC	CD	CE	CF