

EXAMINED BY: <i>Jony Chen</i>	MITSUTECH INTERNATIONAL CORPORATION	FILE NO . CAS-10044
APPROVED BY: <i>David Chang</i>		ISSUE : OCT.29,1999
		TOTAL PAGE : 7
		VERSION : 2

CUSTOMER ACCEPTANCE SPECIFICATIONS

MODEL NO. :

16400(REFLECTIVE TYPES)

FOR MESSRS :

CUSTOMER'S APPROVAL

DATE :

BY :

MODEL NO.	VERSION
16400(REFLECTIVE TYPES)	2

NUMBERING SYSTEM

Polarizer Mode	Backlight	Code value
Reflective	—	R

E W 16 4 00 G R

LCD type + color	Code Value
STN + Yellow-Green	Y
STN + Gray	G
FSTN+ White	F

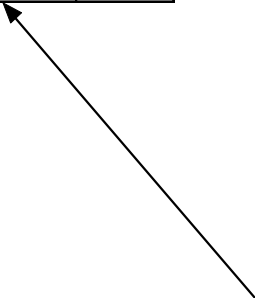
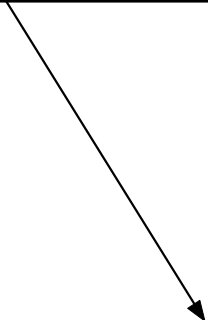

TABLE OF CONTENTS

NO.	ITEM	PAGE
=====		
1.	GENERAL SPECIFICATIONS -----	1
2.	MECHANICAL SPECIFICATIONS -----	1
3.	ABSOLUTE MAXIMUM RATINGS -----	2
4.	ELECTRICAL CHARACTERISTICS -----	3
5.	OPTICAL CHARACTERISTICS -----	3
6.	OUTLINE DIMENSION -----	4
7.	DETAIL DRAWING OF DOT MATRIX -----	5
8.	BLOCK DIAGRAM -----	5
9.	INTERFACE SIGNALS -----	6
10.	POWER SUPPLY -----	7
11.	DISPLAY DATA RAM ADDRESS -----	7

1. GENERAL SPECIFICATIONS

1.1 GENERAL SPECIFICATIONS

PLEASE REFER TO :

CUSTOMER ACCEPTANCE STANDARD SPECIFICATIONS :

E U - 0 0 2 A

1.2 APPLICATION NOTES FOR CONTROLLER / DRIVER :

PLEASE REFER TO :

CUSTOMER ACCEPTANCE STANDARD SPECIFICATIONS :

E U - K S 0 0 6 6

1.3 THIS INDIVIDUAL SPECIFICATIONS IS PRIOR TO GENERAL SPECIFICATIONS .

2. MECHANICAL SPECIFICATIONS

- | | | |
|-------------------------|-------|---------------------------------|
| (1) NUMBER OF CHARACTER | ----- | 16 CH * 4 LINES |
| (2) MODULE SIZE | ----- | 87.0W * 60.0H * 10.0D (max.) mm |
| (3) EFFECTIVE AREA | ----- | 61.8W * 25.2H mm |
| (4) CHARACTER FONT | ----- | 5 * 7 DOTS + CURSOR |
| (5) CHARACTER SIZE | ----- | 2.95W * 4.75H mm |
| (6) CHARACTER PITCH | ----- | 3.55W * 5.35H mm |
| (7) DOT SIZE | ----- | 0.55W * 0.55H mm |
| (8) DOT PITCH | ----- | 0.60W * 0.60H mm |
| (9) LCD TYPE * | | |
| (10) DRIVING METHOD | ----- | 1 / 16 DUTY MULTIPLEX DRIVE |

* PLEASE REFER TO NUMBERING SYSTEM

3. ABSOLUTE MAXIMUM RATINGS

3.1 ELECTRICAL ABSOLUTE MAXIMUM RATINGS . (AT Ta = 25 °C)

PARAMETER	SYMBOL	MIN .	MAX .	UNIT	REMARK
POWER SUPPLY FOR LOGIC	VDD - VSS	0	7.0	V	
POWER SUPPLY FOR LCD DRIVE	VDD - VO	0	13.0	V	
INPUT VOLTAGE	VI	VSS	VDD	V	
STATIC ELECTRICITY	—	—	100	V	NOTE (1)

NOTE (1) : TEST METHOD AND CONDITIONS :
 AFTER CHARGING UP 200 PF CAPACITOR BY STATED VOLTAGE ,
 THE CAPACITOR IS CONNECTED WITH INTERFACE PINS OF THE
 MODULE .

3.2 ENVIRONMENTAL ABSOLUTE MAXIMUM RATINGS .

I T E M	OPERATING		STORAGE		REMARK
	MIN .	MAX .	MIN .	MAX .	
AMBIENT TEMPERATURE	- 20 °C	70 °C	- 30 °C	80 °C	NOTE (2) , (3)
HUMIDITY	—	90 % RH	—	90 % RH	WITHOUT CONDENSATION
VIBRATION	—	4.9 m/s ² (0.5 G)	—	19.6 m/s ² (2 G)	
SHOCK	—	29.4 m/s ² (3 G)	—	490.0 m/s ² (50 G)	XYZ DIRECTIONS
CORROSIVE GAS	NOT ACCEPTABLE		NOT ACCEPTABLE		

NOTE (2) : Ta AT -30°C : 48HR MAX .
 80°C : 168HR MAX .

NOTE (3) : BACKGROUND COLOR CHANGES SLIGHTLY DEPENDING ON AMBIENT
 TEMPERATURE THIS PHENOMENON IS REVERSIBLE .

4. ELECTRICAL CHARACTERISTICS

Ta = 25 °C

VDD = 5.0 ± 0.25 V

PARAMETER	SYMBOL	CONDITION	MIN.	TYP.	MAX.	UNIT
H LEVEL INPUT VOLTAGE	VIH	—	2.2	—	—	V
L LEVEL INPUT VOLTAGE	VIL	—	—	—	0.6	V
H LEVEL OUTPUT VOLTAGE	VOH	-IOH = 0.2 mA	2.4	—	—	V
L LEVEL OUTPUT VOLTAGE	VOL	IOL = 1.2 mA	—	—	0.4	V
POWER SUPPLY CURRENT (LOGIC)	IDD	VDD = 5.0 V	—	2.0	5.0	mA
RECOMMENDED LCD DRIVING VOLTAGE	VDD - VO ∅ = 10° θ = 0° DUTY = 1/16	Ta = -20 °C	—	4.4	—	V
		Ta = 25 °C	—	4.4	—	V
		Ta = 70 °C	—	4.4	—	V
CLOCK OSCILLATION FREQUENCY	FOSC	Ta = 25 °C	—	270	—	KHZ

5. OPTICAL CHARACTERISTICS.

Ta = 25 °C

VDD = 5.0 V

I T E M		SYMBOL	CONDITION	MIN.	TYP.	MAX.	UNIT	NOTE
VIEWING AREA	STN	∅ 2 - ∅ 1	K ≥ 1.4	30	—	—	deg.	1
	FSTN			40	—	—	deg.	1
CONTRAST RATIO	STN	K	∅ = 10° θ = 0°	5	—	—	—	1
	FSTN			6	—	—	—	1
RESPONSE TIME	tr (rise)	∅ = 10° θ = 0°	Ta = -20°C	—	5538	—	ms	1
			Ta = 25°C	—	228	—		
			Ta = 70°C	—	104	—		
	tf (fall)		Ta = -20°C	—	2316	—		
			Ta = 25°C	—	174	—		
			Ta = 70°C	—	85	—		

NOTE (1): PLEASE REFER TO :
CUSTOMER ACCEPTANCE STANDARD SPECIFICATION : EU-002A

MODEL NO.	VERSION	PAGE
16400(REFLECTIVE TYPES)	2	4

6. OUTLINE DIMENSION

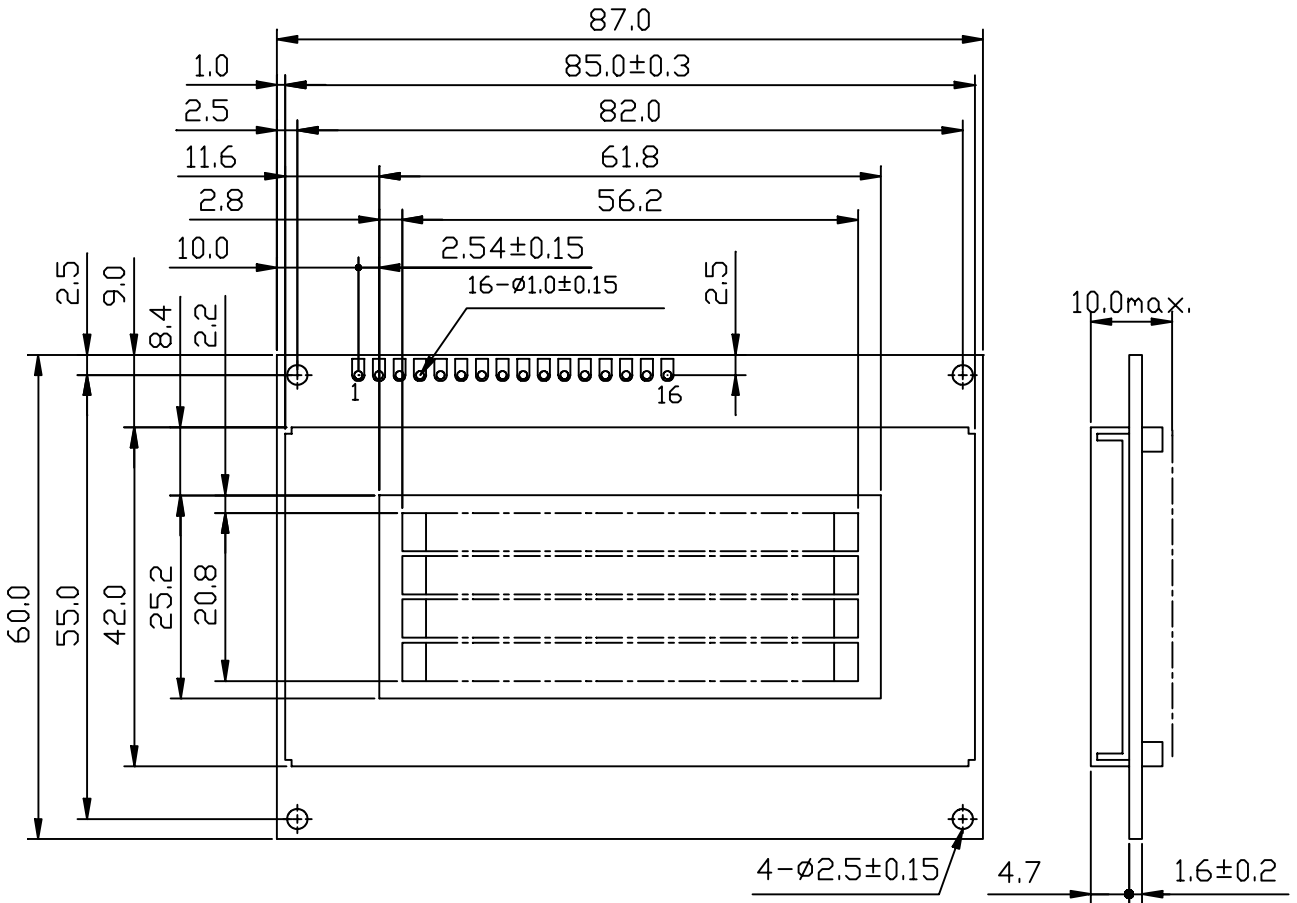

UNIT : mm
 SCALE : NTS
 NOT SPECIFIED TOLERANCE IS ± 0.5mm

7. DETAIL DRAWING OF DOT MATRIX

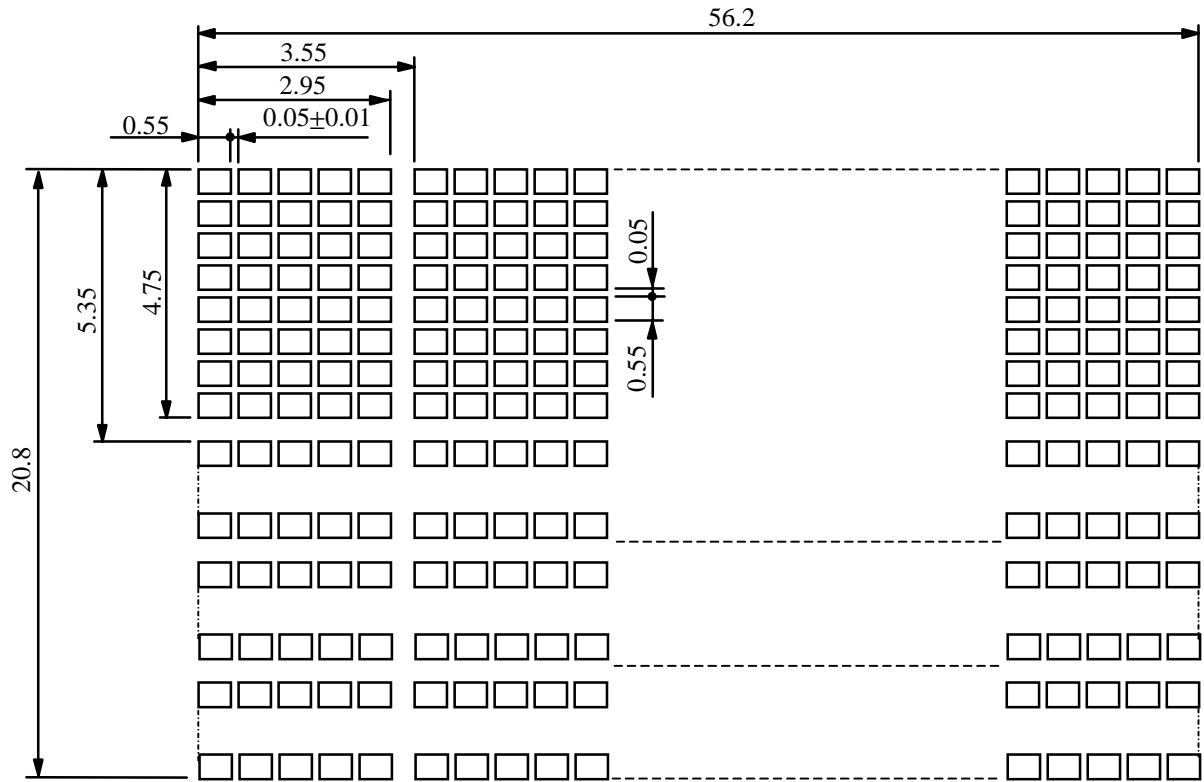

UNIT : mm
 SCALE : NTS
 NOT SPECIFIED TOLERANCE IS ± 0.1

8. BLOCK DIAGRAM

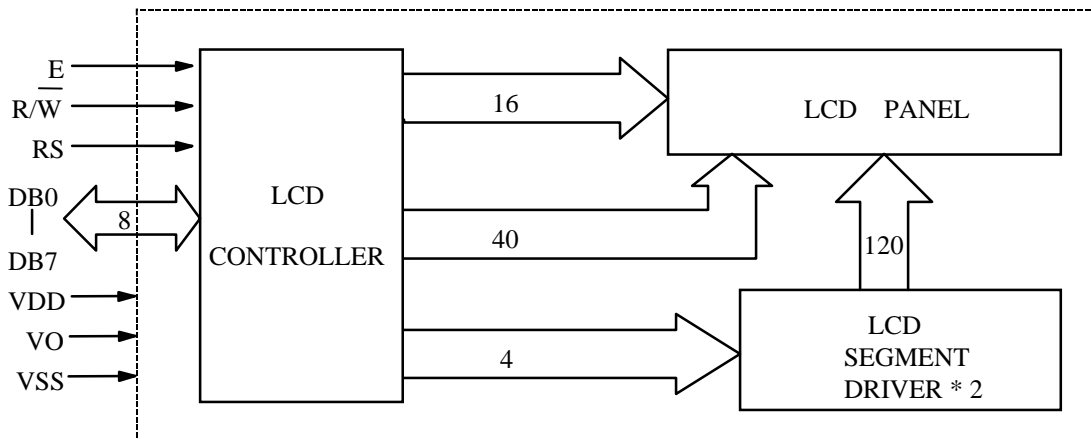

9. INTERFACE SIGNALS

PIN NO.	SYMBOL	DESCRIPTION	FUNCTION
1	VSS	GROUND	0V (GND)
2	VDD	POWER SUPPLY FOR LOGIC CIRCUIT	+5V
3	VO	LCD CONTRAST ADJUSTMENT	
4	RS	INSTRUCTION/DATA REGISTER SELECTION	RS = 0 : INSTRUCTION REGISTER RS = 1 : DATA REGISTER
5	R/\overline{W}	READ/WRITE SELECTION	$R/\overline{W} = 0$: REGISTER WRITE $R/\overline{W} = 1$: REGISTER READ
6	E	ENABLE INPUT	
7	DB0	DATA INPUT/OUTPUT LINES	4 BIT/8BIT SELECTABLE 4 BIT : DB4 - DB7 8 BIT : DB0 - DB7
8	DB1		
9	DB2		
10	DB3		
11	DB4		
12	DB5		
13	DB6		
14	DB7		
15	NC	NO CONNECTION	
16	NC		

10. POWER SUPPLY

10.1 POWER SUPPLY FOR LCD MODULE

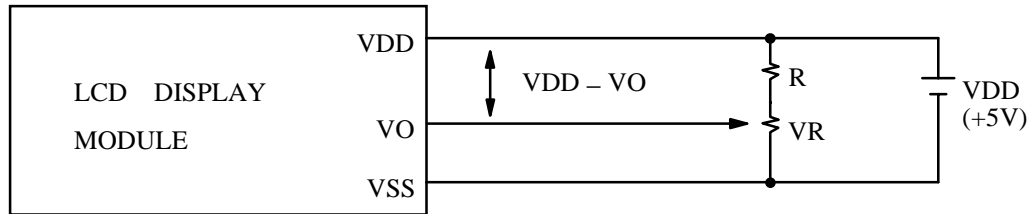

VDD - VO : LCD DRIVING VOLTAGE

VR : 10KΩ ~ 20KΩ

RECOMMENDED RESISTOR R : $VDD - VO \geq 1.5V$

11. DISPLAY DATA RAM ADDRESS

CHARACTER	1	2	3	4	5	6	7	8	9	10	11	12	13	14	15	16
LINE 1	80	81	82	83	84	85	86	87	88	89	8A	8B	8C	8D	8E	8F
LINE 2	C0	C1	C2	C3	C4	C5	C6	C7	C8	C9	CA	CB	CC	CD	CE	CF
LINE 3	90	91	92	93	94	95	96	97	98	99	9A	9B	9C	9D	9E	9F
LINE 4	D0	D1	D2	D3	D4	D5	D6	D7	D8	D9	DA	DB	DC	DD	DE	DF