

EXAMINED BY: <i>Jony Chen</i>	mitsutech INTERNATIONAL CORPORATION	FILE NO . CAS-10078
APPROVED BY: <i>David Chang</i>		ISSUE : JAN.24,2000
		TOTAL PAGE : 8
		VERSION : 4

CUSTOMER	ACCEPTANCE	SPECIFICATIONS
----------	------------	----------------

MODEL NO. :

24B00(REFLECTIVE TYPES)

FOR MESSRS :

CUSTOMER'S APPROVAL

DATE :

BY :

MITSUTECH INT'L CORP.

MODEL NO.	VERSION
24B00(REFLECTIVE TYPES)	4

DOC . FIRST ISSUE	MAR.26,1998
-------------------	-------------

RECORDS OF REVISION		
DATE	REVISED PAGE NO.	SUMMARY
NOV.11, 1998	1	2. MECHANICAL SPECIFICATIONS (2) MODULE SIZE 11.5D → 12.0D
	3	4. ELECTRICAL CHARACTERISTICS THE NUMBERS OF "RECOMMENDED LCD DRIVING VOLTAGE" REVISED AS BELOW : W.T. Ta = -20 °C 10.8 → 12.0 Ta = 25 °C 9.6 → 12.0 Ta = 70 °C 8.8 → 12.0
	6	6. OUTLINE DIMENSION : 11.5 MAX. → 12.0 MAX.
MAR.25,1999	3	4. ELECTRICAL CHARACTERISTICS THE NUMBERS OF "RECOMMENDED LCD DRIVING VOLTAGE" REVISED AS BELOW : W.T. Ta = -20 °C 12.0 → 13.9 Ta = 25 °C 12.0 → 12.1 Ta = 70 °C 12.0 → 11.1
JAN.24,2000	1~4	THE ENTIRE PAGES REVISED.

MODEL NO.	VERSION
24B00(REFLECTIVE TYPES)	4

NUMBERING SYSTEM

Polarizer Mode	Backlight	Code value
Reflective	—	R

E W 2 4 B 0 0 G R

LCD type + color	Code Value
STN + Yellow-Green	Y
STN + Gray	G
FSTN + White	F

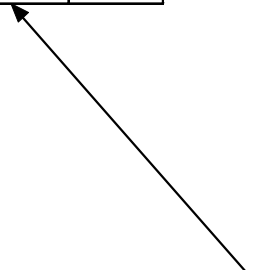
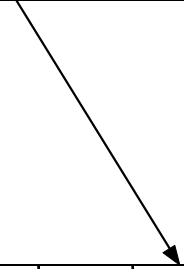

TABLE OF CONTENTS

NO.	ITEM	PAGE
=====		
1.	GENERAL SPECIFICATIONS -----	1
2.	MECHANICAL SPECIFICATIONS -----	1
3.	ABSOLUTE MAXIMUM RATINGS -----	2
4.	ELECTRICAL CHARACTERISTICS -----	3
5.	OPTICAL CHARACTERISTICS -----	4
6.	OUTLINE DIMENSION -----	5
7.	DETAIL DRAWING OF DOT MATRIX -----	6
8.	BLOCK DIAGRAM -----	6
9.	INTERFACE SIGNALS -----	7
10.	POWER SUPPLY -----	8

1. GENERAL SPECIFICATIONS

1.1 GENERAL SPECIFICATIONS

PLEASE REFER TO :

CUSTOMER ACCEPTANCE STANDARD SPECIFICATIONS :

E U - 0 0 2 A

1.2 APPLICATION NOTES FOR CONTROLLER

PLEASE REFER TO :

CUSTOMER ACCEPTANCE STANDARD SPECIFICATIONS :

E U - T 6 9 6 3 C

1.3 THIS INDIVIDUAL SPECIFICATION IS PRIOR TO GENERAL SPECIFICATIONS .

2. MECHANICAL SPECIFICATIONS

- | | | |
|--------------------|-------|----------------------------------|
| (1) NUMBER OF DOTS | ----- | 240W * 64H DOTS |
| (2) MODULE SIZE | ----- | 180.0W * 65.0H * 12.0D (max.) mm |
| (3) EFFECTIVE AREA | ----- | 133.0W * 40.0H mm |
| (4) ACTIVE AREA | ----- | 127.16W * 33.88H mm |
| (5) DOT SIZE | ----- | 0.49W * 0.49H mm |
| (6) DOT PITCH | ----- | 0.53W * 0.53H mm |
| (7) LCD TYPE * | | |
| (8) DRIVING METHOD | ----- | 1 / 64 DUTY MULTIPLEX DRIVE |

* PLEASE REFER TO NUMBERING SYSTEM .

3. ABSOLUTE MAXIMUM RATINGS

3.1 ELECTRICAL ABSOLUTE MAXIMUM RATINGS.

PARAMETER	SYMBOL	MIN.	MAX.	UNIT	REMARK
POWER SUPPLY FOR LOGIC	VDD - VSS	0	6.5	V	
POWER SUPPLY FOR LCD DRIVING	VDD - VEE	0	22.0	V	
INPUT VOLTAGE	VI	VSS	VDD	V	
STATIC ELECTRICITY	—	—	100	V	NOTE (1)

NOTE (1) : TEST METHOD AND CONDITIONS :
 AFTER CHARGING UP 200 PF CAPACITOR BY STATED VOLTAGE ,
 THE CAPACITOR IS CONNECTED WITH INTERFACE PINS OF THE
 MODULE .

3.2 ENVIRONMENTAL ABSOLUTE MAXIMUM RATINGS .

I T E M	OPERATING		STORAGE		REMARK
	MIN.	MAX.	MIN.	MAX.	
AMBIENT TEMPERATURE	-20 °C	70 °C	-30 °C	80 °C	NOTE (2), (3)
HUMIDITY	—	85 % RH	—	85 % RH	WITHOUT CONDENSATION
VIBRATION	—	4.9 m/s ² (0.5 G)	—	19.6 m/s ² (2 G)	10~100 HZ XYZ DIRECTIONS 1 Hr. EACH
SHOCK	—	29.4 m/s ² (3 G)	—	490.0 m/s ² (50 G)	10 mSECONDS XYZ DIRECTIONS 1 TIME EACH
CORROSIVE GAS	NOT ACCEPTABLE		NOT ACCEPTABLE		

NOTE (2) : Ta AT -30°C : 48HR MAX .
 80°C : 168HR MAX .

NOTE (3) : BACKGROUND COLOR CHANGES SLIGHTLY DEPENDING ON AMBIENT
 TEMPERATURE THIS PHENOMENON IS REVERSIBLE .

4. ELECTRICAL CHARACTERISTICS

PARAMETER	SYMBOL	CONDITION	MIN .	TYP .	MAX .	UNIT
POWER SUPPLY VOLTAGE FOR LOGIC	VDD - VSS	—	4.75	5.0	5.25	V
POWER SUPPLY VOLTAGE FOR LCD DRIVE	VEE - VSS	—	- 2.0	—	- 10.0	V
INPUT VOLTAGE NOTE (1)	VIH	H LEVEL	VDD - 2.2	—	VDD	V
	VIL	L LEVEL	0	—	0.8	V
OUTPUT VOLTAGE NOTE (1)	VOH	H LEVEL	VDD - 0.3	—	VDD	
	VOL	L LEVEL	0	—	0.3	
POWER SUPPLY CURRENT FOR LOGIC NOTE (2)	IDD	VDD - VSS = 5.0 V VDD - VEE = 8.7 V	—	9.0	—	mA
RECOMMENDED LCD DRIVING VOLTAGE NOTE (3)	VDD-VEE $\varnothing = 10^\circ \theta = 0^\circ$ DUTY=1/64	Ta = -20 °C	—	8.7	—	V
		Ta = 25 °C	—	8.7	—	V
		Ta = 70 °C	—	7.9	—	V
CLOCK OSCILLATION FREQUENCY	f OSC	—	—	3.58	—	MHZ

NOTE (1): APPLIED TO TERMINALS (WR, RD, CE, C/D, RST, FS, D0~D7)

NOTE (2): THE DISPLAY PATTERN IS ALL "OFF"/"ON"

NOTE (3): RECOMMENDED LCD DRIVING VOLTAGE MAY FLUCTUATE ABOUT ± 0.5 V BY EACH MODULE

5. OPTICAL CHARACTERISTICS

Ta = 25 °C

VDD = 5.0 V

I T E M		SYMBOL	CONDITION	MIN.	TYP.	MAX.	UNI T	NOTE
VIEWING AREA	STN	∅2 - ∅1	K ≥ 1.4	40	—	—	deg.	1
	FSTN			50	—	—	deg.	1
CONTRAST RATIO	STN	K	∅ = 10° θ = 0°	—	5	—	—	1
	FSTN			5	—	—	—	1
RESPONSE TIME	tr (rise)	∅ = 10° θ = 0°	Ta = -20°C	—	3982	—	ms	1
			Ta = 25°C	—	228	—		
			Ta = 70°C	—	83	—		
	tf (fall)		Ta = -20°C	—	3752	—		
			Ta = 25°C	—	176	—		
			Ta = 70°C	—	94	—		

NOTE (1) : PLEASE REFER TO :
 CUSTOMER ACCEPTANCE STANDARD SPECIFICATIONS.
 E U - 0 0 2 A

NOTE (2) : POLARIZER MODE : TRANSFLECTIVE

NOTE (3) : POLARIZER MODE : TRANSMISSIVE

6. OUTLINE DIMENSION

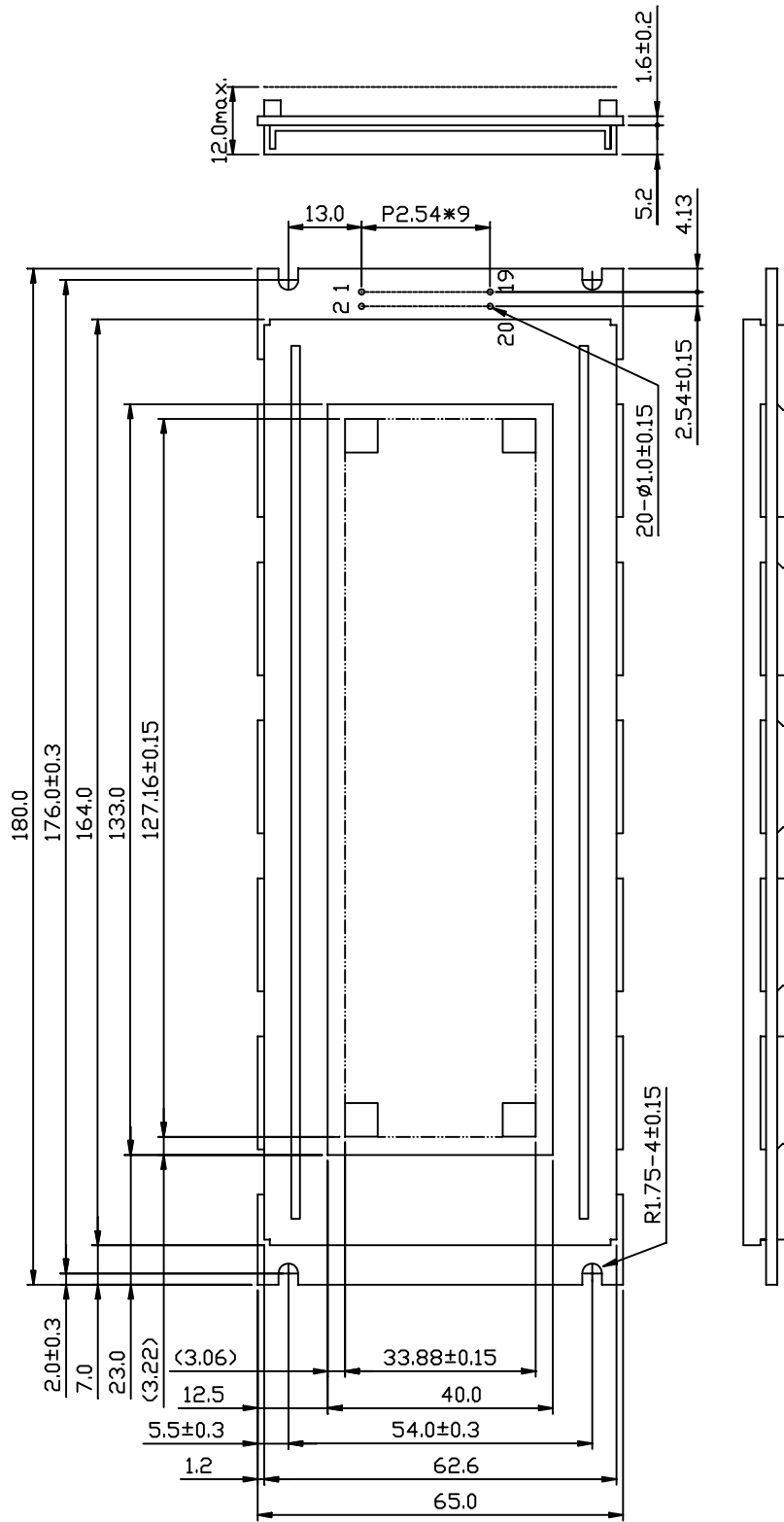

UNIT : mm
SCALE : NTS
NOT SPECIFIED TOLERANCE IS ± 0.5

7. DETAIL DRAWING OF DOT MATRIX

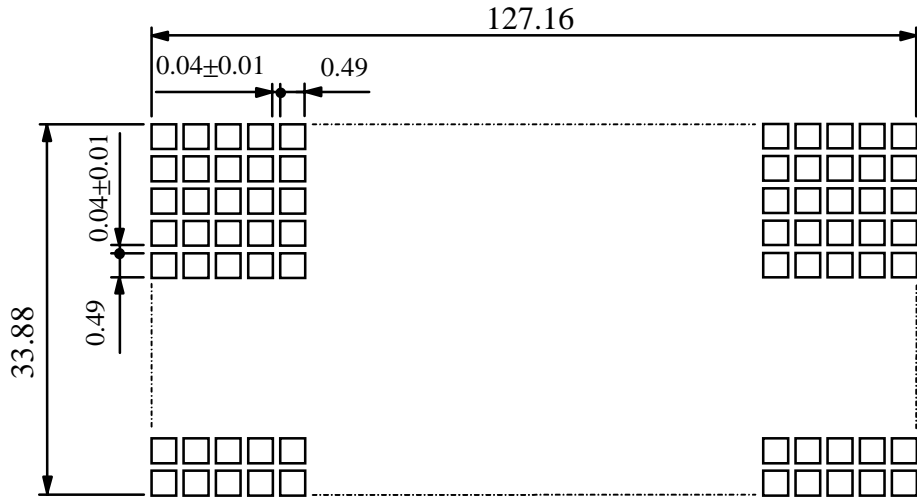

UNIT : mm
 SCALE : NTS
 NOT SPECIFIED TOLERANCE IS ± 0.1

8. BLOCK DIAGRAM

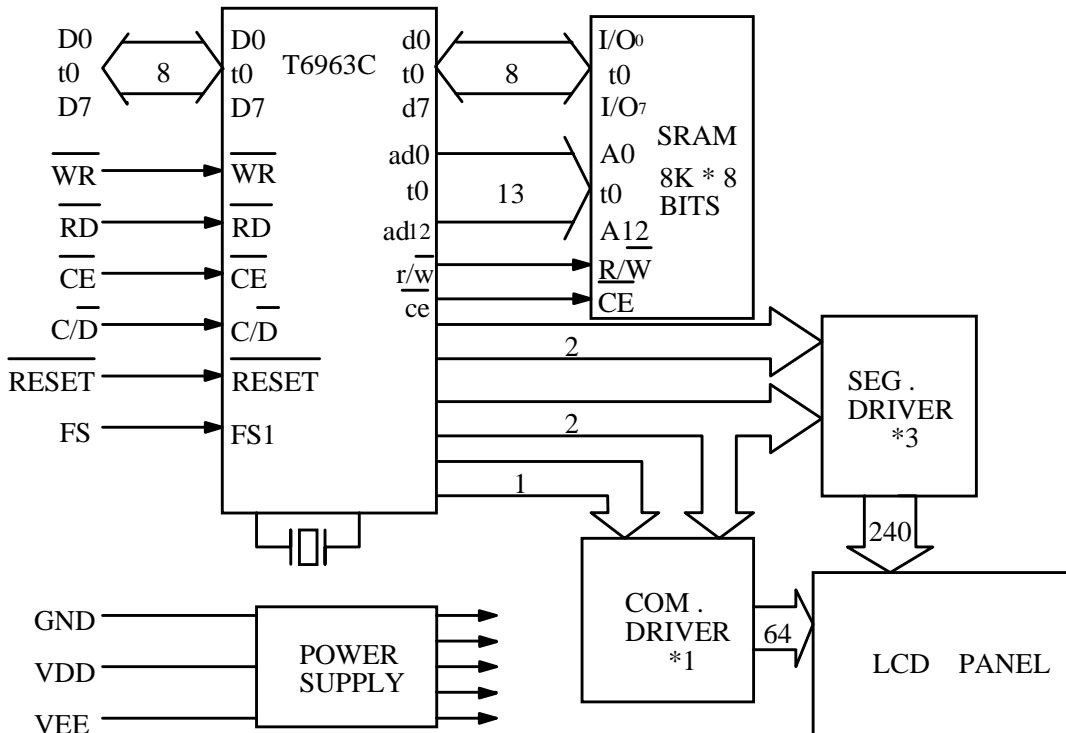

9. INTERFACE SIGNALS

PIN NO.	SIGNAL	FUNCTION
1	FGND	FRAME GROUND (0V)
2	GND	GROUND
3	VDD	POWER SUPPLY FOR LOGIC (+5V)
4	VEE	POWER SUPPLY FOR LCD DRIVER
5	$\overline{\text{WR}}$	DATA WRITE
6	$\overline{\text{RD}}$	DATA READ
7	$\overline{\text{CE}}$	CHIP ENABLE
8	$\overline{\text{C/D}}$	$\overline{\text{WR}} = "L", \overline{\text{C/D}} = "H" : \text{COMMAND WRITE}$ $\text{---} \quad \text{C/D} = "L" : \text{DATA WRITE}$ $\text{RD} = "L", \text{C/D} = "H" : \text{STATUS READ}$ $\text{C/D} = "L" : \text{DATA READ}$
9	NC	—————
10	$\overline{\text{RESET}}$	CONTROLLER RESET
11~18	D0~D7	DATA INPUT/OUTPUT
19	FS	FONT SELECT : CONNECT TO VDD : 6*8 PIXEL/FONT CONNECT TO GND : 8*8 PIXEL/FONT
20	NC	—————

10. POWER SUPPLY

10.1 POWER SUPPLY FOR LCM

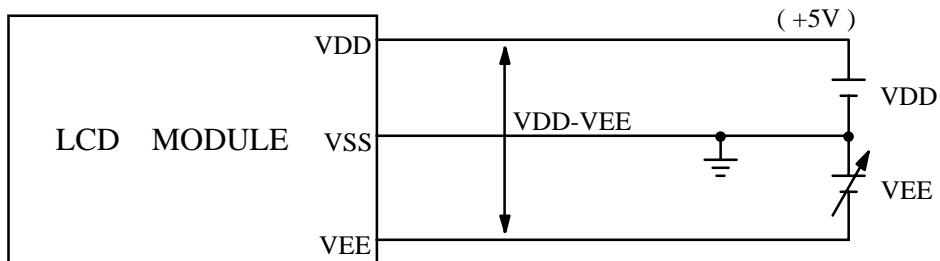

VDD-VEE : LCD DRIVING VOLTAGE

10.2 TIMING OF POWER SUPPLY AND INTERFACE SIGNAL

