

EXAMINED BY : <i>Jony Chen</i>	<p style="text-align: center;">MITSUTECH</p> <p style="text-align: center;">INTERNATIONAL CORPORATION</p>	FILE NO . CAS-10093
APPROVED BY: <i>David Chang</i>		ISSUE : JAN.24,2000
		TOTAL PAGE : 8
		VERSION : 3

CUSTOMER
ACCEPTANCE
SPECIFICATIONS

MODEL NO . :

24B00(CCFL TYPES)

FOR MESSRS :

CUSTOMER'S APPROVAL

DATE :

BY :

MITSUTECH INT'L CORP.

MODEL NO . 24B00(CCFL TYPES)	VERSION 3
---------------------------------	--------------

RECORDS OF REVISION	DOC . FIRST ISSUE APR.03,1998
---------------------	----------------------------------

DATE	REVISED PAGE NO.	SUMMARY
MAR.25,1999	3	4. ELECTRICAL CHARACTERISTICS THE NUMBERS OF "RECOMMENDED LCD DRIVING VOLTAGE" REVISED AS BELOW : W.T. Ta = -20 °C 10.8 → 13.9 Ta = 25 °C 9.6 → 12.1 Ta = 60 °C 8.8 → 11.3
JAN.24,2000	1~4	THE ENTIRE PAGES REVISED.

NUMBERING SYSTEM

Polarizer Mode	Backlight	Code value
Transflective	CCFL	D
Transmissive	CCFL	C

Backlight Color	Code Value
White	W

E	W	24	B	00	B	C	W
---	---	----	---	----	---	---	---

LCD type + LCD color	Code Value
STN + Yellow-Green	Y
STN + Gray	G
STN + Blue	B
FSTN + White	F
FSTN + Black	N

TABLE OF CONTENTS

NO.	ITEM	PAGE
1.	GENERAL SPECIFICATIONS -----	1
2.	MECHANICAL SPECIFICATIONS -----	1
3.	ABSOLUTE MAXIMUM RATINGS -----	2
4.	ELECTRICAL CHARACTERISTICS -----	3
5.	OPTICAL CHARACTERISTICS -----	4
6.	OUTLINE DIMENSION -----	5
7.	DETAIL DRAWING OF DOT MATRIX -----	6
8.	BLOCK DIAGRAM -----	6
9.	INTERFACE SIGNALS -----	7
10.	POWER SUPPLY -----	8

MODEL NO .	VERSION	PAGE
24B00(CCFL TYPES)	3	1

1. GENERAL SPECIFICATIONS

1.1 QUALITY SPECIFICATIONS

PLEASE REFER TO :

CUSTOMER ACCEPTANCE STANDARD SPECIFICATIONS :

E U - 0 0 2 A

1.2 APPLICATION NOTES FOR CONTROLLER / DRIVER :

PLEASE REFER TO :

CUSTOMER ACCEPTANCE STANDARD SPECIFICATIONS :

E U - T 6 9 6 3 C

1.3 THIS INDIVIDUAL SPECIFICATIONS IS PRIOR TO GENERAL SPECIFICATIONS .

2. MECHANICAL SPECIFICATIONS

- (1) NUMBER OF DOTS ----- 240W * 64H DOTS
- (2) MODULE SIZE ----- 187.0W * 76.0H * 14.0D (max .) mm
- (3) EFFECTIVE AREA ----- 133.0W * 40.0H mm
- (4) ACTIVE AREA ----- 127.16W * 33.88H mm
- (5) DOT SIZE ----- 0.49W * 0.49H mm
- (6) DOT PITCH ----- 0.53W * 0.53H mm
- (7) LCD TYPE *
- (8) DRIVING METHOD ----- 1 / 64 DUTY MULTIPLEX DRIVE
- (9) BACK LIGHT ----- CCFL, COLOR : WHITE

3. ABSOLUTE MAXIMUM RATINGS

3.1 ELECTRICAL ABSOLUTE MAXIMUM RATINGS . (AT Ta = 25 °C)

PARAMETER	SYMBOL	MIN .	MAX .	UNIT	REMARK
POWER SUPPLY FOR LOGIC	VDD – VSS	0	7.0	V	
POWER SUPPLY FOR LCD DRIVE	VDD – VEE	0	22.0	V	
INPUT VOLTAGE	VI	VSS	VDD	V	
STATIC ELECTRICITY	—	—	100	V	NOTE (1)

NOTE (1) : TEST METHOD AND CONDITIONS :

AFTER CHARGING UP 200 PF CAPACITOR BY STATED VOLTAGE ,
THE CAPACITOR IS CONNECTED WITH INTERFACE PINS OF THE
MODULE .

3.2 ENVIRONMENTAL ABSOLUTE MAXIMUM RATINGS .

I T E M	OPERATING		STORAGE		REMARK
	MIN .	MAX .	MIN .	MAX .	
AMBIENT TEMPERATURE	-20°C	70°C	-30°C	80°C	NOTE (2), (3)
HUMIDITY	—	85 % RH	—	85 % RH	WITHOUT CONDENSATION
VIBRATION	—	4.9 m/s ² (0.5 G)	—	19.6 m/s ² (2 G)	10~300 HZ XYZ DIRECTIONS 1 Hr EACH
SHOCK	—	29.4 m/s ² (3 G)	—	490.0 m/s ² (50 G)	10 m SEC XYZ DIRECTIONS 1 TIME EACH
CORROSIVE GAS	NOT ACCEPTABLE		NOT ACCEPTABLE		

NOTE (2) : Ta AT -30°C: 48HR MAX .

80°C : 168HR MAX .

NOTE (3) : BACKGROUND COLOR CHANGES SLIGHTLY DEPENDING ON AMBIENT
TEMPERATURE THIS PHENOMENON IS REVERSIBLE .

NOTE (4) : CCFL BACKLIGHT IS NOT AVAILABLE TO FUNCTION BELOW 0°C

4. ELECTRICAL CHARACTERISTICS

PARAMETER		SYMBOL	CONDITION	MIN.	TYP.	MAX.	UNIT
POWER SUPPLY VOLTAGE FOR LOGIC		VDD-VSS	—	4.75	5.0	5.25	V
POWER SUPPLY VOLTAGE FOR LCD DRIVE		VEE-VSS	—	-2.0	—	-10.0	V
INPUT VOLTAGE NOTE (1)	VIH	H LEVEL	VDD - 2.2	—	VDD	V	
	VIL	L LEVEL	0	—	0.8	V	
OUTPUT VOLTAGE NOTE (1)	VOH	H LEVEL	VDD - 0.3	—	VDD		
	VOL	L LEVEL	0	—	0.3		
POWER SUPPLY CURRENT FOR LOGIC NOTE (2)		IDD	VDD - VSS = 5.0 V VDD - VEE = 8.7 V	—	9.0	—	mA
RECOMMENDED LCD DRIVING VOLTAGE NOTE (3)	VDD-VEE $\varnothing = 10^\circ$ $\theta = 0^\circ$ DUTY=1/64	Ta = -20 °C	—	8.7	—	V	
		Ta = 25 °C	—	8.7	—	V	
		Ta = 70 °C	—	7.9	—	V	
CLOCK OSCILLATION FREQUENCY		f OSC	—	—	3.58	—	MHZ
POWER	VOLTAGE	VCCFL	—	—	300	—	Vrms
SUPPLY FOR	FREQUENCY	fCCFL	—	—	30K	—	HZ
CCFL	CURRENT	IL	—	—	5	—	mA

NOTE (1): APPLIED TO TERMINALS (WR, RD, CE, C/D, RST, FS, D0~D7)

NOTE (2): THE DISPLAY PATTERN IS ALL "OFF"/"ON"

NOTE (3): RECOMMENDED LCD DRIVING VOLTAGE MAY FLUCTUATE ABOUT ± 0.5 V BY EACH MODULE

5. OPTICAL CHARACTERISTICS

Ta = 25 °C

VDD = 5.0 V

I T E M		SYMBOL	CONDITION	MIN .	TYP .	MAX.	UNIT	NOTE
VIEWING AREA	STN	∅ 2 - ∅ 1	K ≥ 1.4	40	—	—	deg.	1
	FSTN			50	—	—	deg.	1
CONTRAST RATIO	STN	K	∅ = 10° θ = 0°	—	5	—	—	1
	FSTN			5	—	—	—	1
RESPONSE TIME	tr (rise)	∅ = 10° θ = 0°	Ta = -20°C	—	3982	—	ms	1
			Ta = 25°C	—	228	—		
			Ta = 70°C	—	83	—		
	tf (fall)		Ta = -20°C	—	3752	—		
			Ta = 25°C	—	176	—		
			Ta = 70°C	—	94	—		
THE BRIGHTNESS OF BACK-LIGHT	B	—	—	160 360	—	cd/m ²	2, 4, 5 3, 4, 5	
RIS TIME OF BACKLIGHT	TC	—	—	5	—	MINUTE	—	
BRIGHTNESS UNIFORMITY	—	—	—	—	—	20	%	6.7

NOTE (1) : PLEASE REFER TO :
 CUSTOMER ACCEPTANCE STANDARD SPECIFICATIONS.
 E U - 0 0 2 A

NOTE (2) : POLARIZER MODE : TRANSFLECTIVE
 NOTE (3) : POLARIZER MODE : TRANSMISSIVE
 NOTE (4) : MEASUREMENT AFTER 10 MINUTES OF CCFL OPERATING.
 NOTE (5) : BRIGHTNESS CONTROL : 100% AND DISPLAY ALL ON.
 NOTE (6) : MEASUREMENT OF THE FOLLOWING 9 PLACES ON THE DISPLAY.
 DEFINITION OF THE BRIGHTNESS TOLERANCE .

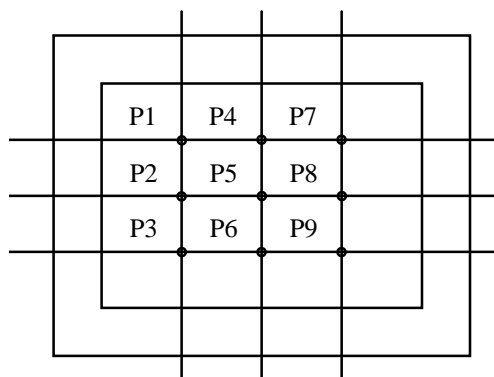

NOTE (7) : BRIGHTNESS UNIFORMITY IS DEFINED AS FOLLOWING

$$\sum X = \left[\frac{(\text{MAXIMUN BRIGHTNESS OR MINIMUN BRIGHTNESS}) - \text{AVERAGE BRIGHTNESS}}{\text{AVERAGE BRIGHTNESS}} \right] \times 100\%$$

MODEL NO .	VERSION	PAGE
24B00(CCFL TYPES)	3	5

6. OUTLINE DIMENSION

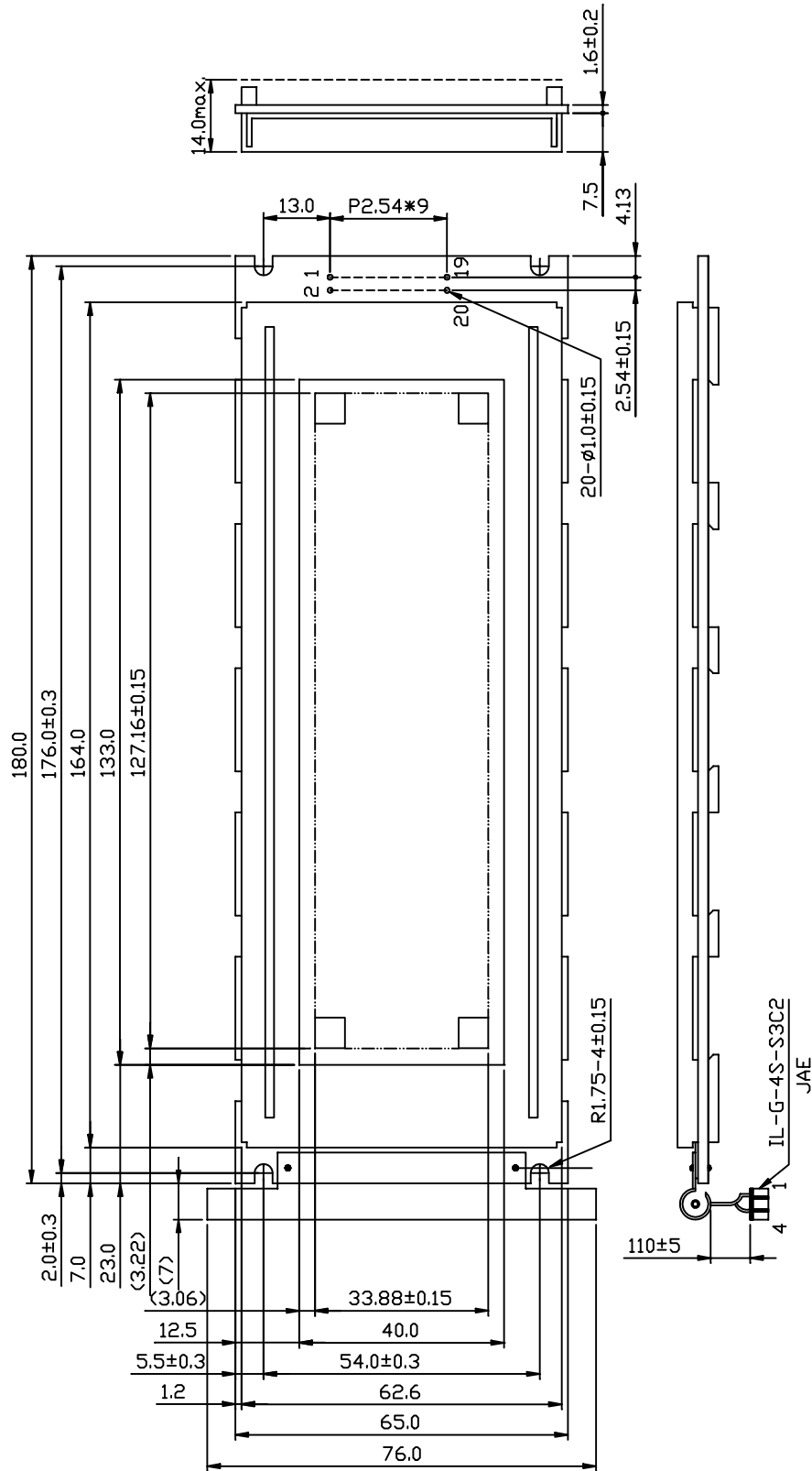

UNIT : mm
 SCALE : NTS
 NOT SPECIFIED TOLERANCE IS ± 0.5

7. DETAIL DRAWING OF DOT MATRIX

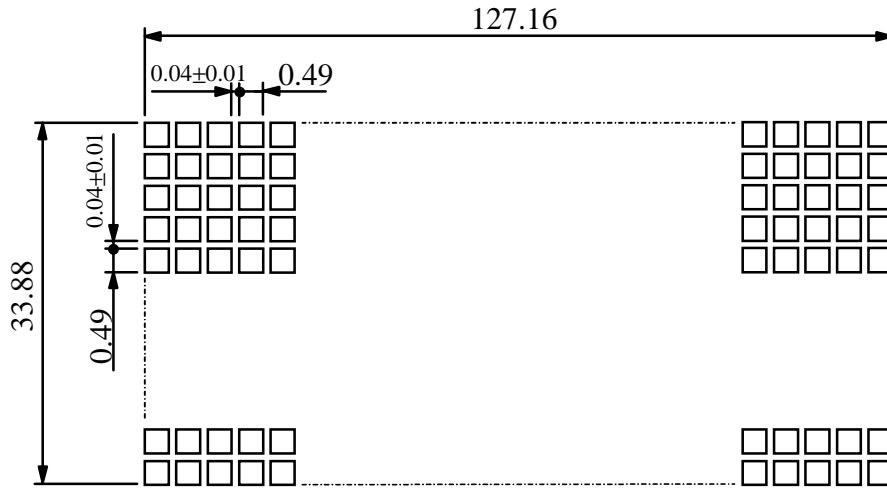

UNIT : mm
 SCALE : NTS
 NOT SPECIFIED TOLERANCE IS ±0.1

8. BLOCK DIAGRAM

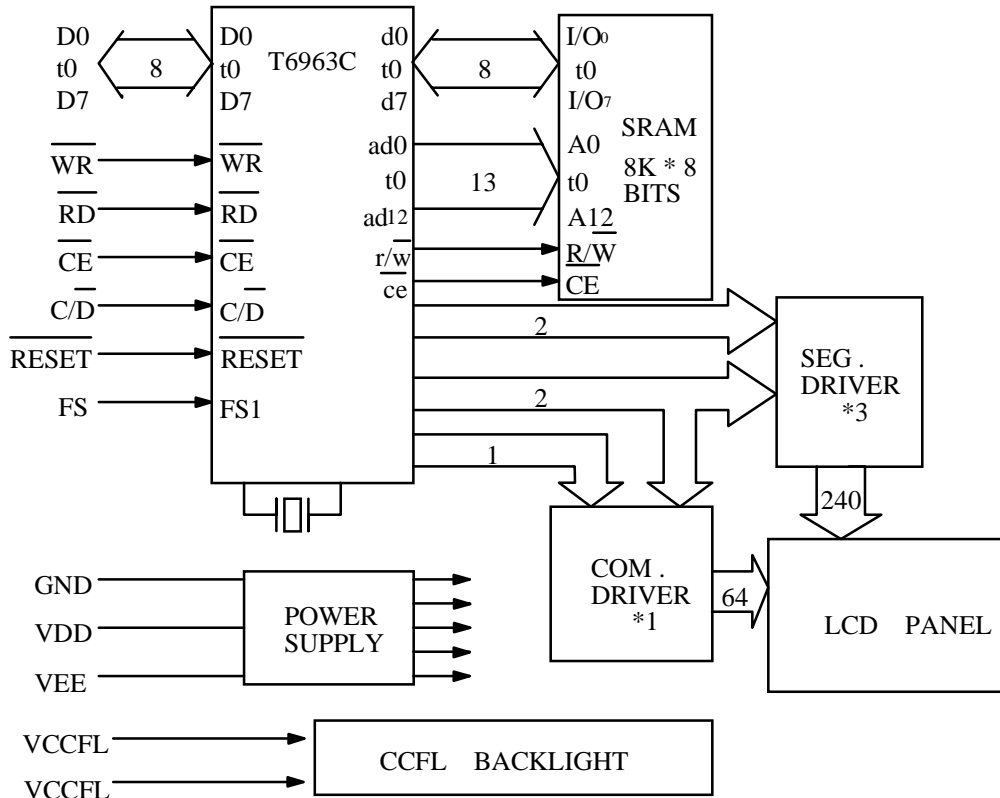

9. INTERFACE SIGNALS

IF1

PIN NO .	SIGNAL	FUNCTION
1	FGND	FRAME GROUND (0V)
2	GND	GROUND
3	VDD	POWER SUPPLY FOR LOGIC (+5V)
4	VEE	POWER SUPPLY FOR LCD DRIVER
5	$\overline{\text{WR}}$	DATA WRITE
6	$\overline{\text{RD}}$	DATA READ
7	$\overline{\text{CE}}$	CHIP ENABLE
8	$\overline{\text{C/D}}$	$\overline{\text{WR}}=\text{"L"}, \overline{\text{C/D}}=\text{"H"}:$ COMMAND WRITE $\overline{\text{C/D}}=\text{"L"}:$ DATA WRITE $\overline{\text{RD}}=\text{"L"}, \overline{\text{C/D}}=\text{"H"}:$ STATUS READ $\overline{\text{C/D}}=\text{"L"}:$ DATA READ
9	NC	—————
10	$\overline{\text{RESET}}$	CONTROLLER RESET
11~18	D0~D7	DATA INPUT/OUTPUT
19	FS	FONT SELECT : CONNECT TO VDD : 6*8 PIXEL/FONT CONNECT TO GND : 8*8 PIXEL/FONT
20	NC	—————

IF2 :

INTERFACE	PIN	SIGNAL	FUNCTION
CCFL	1	VCCFL	POWER SUPPLY FOR CCFL DRIVING
	2~3	NC	NO CONNECTION
	4	VCCFL	POWER SUPPLY FOR CCFL DRIVING

10. POWER SUPPLY

10.1 POWER SUPPLY FOR LCD MODULE

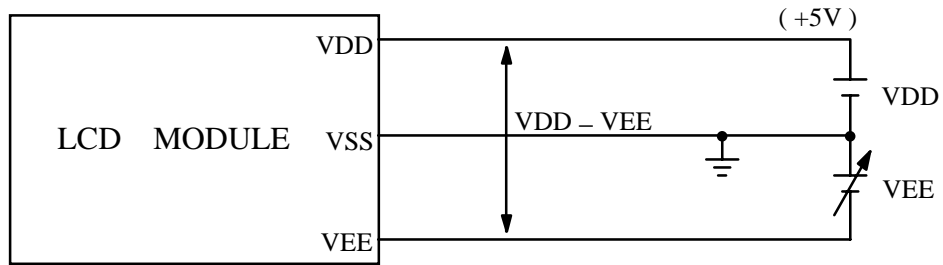

VDD-VEE : LCD DRIVING VOLTAGE

10.2 POWER SUPPLY FOR CCFL BACK-LIGHT

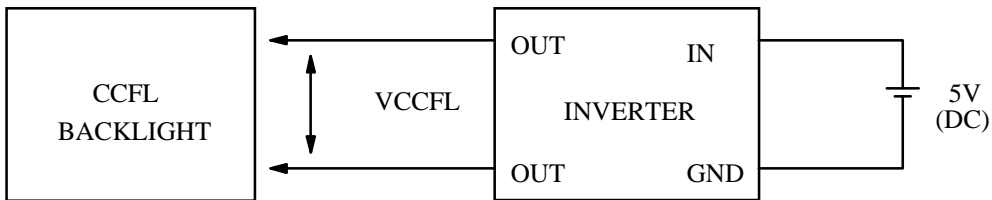

RECOMMENDED INVERTER : IA-EM02A

10.3 POWER AND INTERFACE TIMING SEQUENCE

