

EXAMINED BY : <i>Jony Chen</i>	<p style="text-align: center;">MTSUTECH</p> <p style="text-align: center;">INTERNATIONAL CORPORATION</p>	FILE NO . CAS- 10077
APPROVED BY: <i>David Chang</i>		ISSUE : JAN.24,2000
		TOTAL PAGE : 8
		VERSION : 4

CUSTOMER ACCEPTANCE SPECIFICATIONS

MODEL NO . :

24B00(LED TYPES)

FOR MESSRS :

CUSTOMER'S APPROVAL

DATE :

BY :

MITSUTECH INT'L CORP.

MODEL NO . 24B00(LED TYPES)	VERSION 4
--------------------------------	--------------

RECORDS OF REVISION	DOC . FIRST ISSUE NOV.28,1997
---------------------	----------------------------------

DATE	REVISED PAGE NO.	SUMMARY
NOV.11, 1998	3	4. ELECTRICAL CHARACTERISTICS THE NUMBERS OF "RECOMMENDED LCD DRIVING VOLTAGE" REVISED AS BELOW : W.T. Ta = -20 °C 10.8 → 12.0 Ta = 25 °C 9.6 → 12.0 Ta = 70 °C 8.8 → 12.0
MAR.25,1999	3	4. ELECTRICAL CHARACTERISTICS THE NUMBERS OF "RECOMMENDED LCD DRIVING VOLTAGE" REVISED AS BELOW : W.T. Ta = -20 °C 12.0 → 13.9 Ta = 25 °C 12.0 → 12.1 Ta = 70 °C 12.0 → 11.1
JAN.24,2000	1~4	THE ENTIRE PAGES REVISED.

NUMBERING SYSTEM

Polarizer Mode	Backlight	Code value
Transflective	LED	L
Transmissive	LED	M

Backlight Color	Code Value
Yellow-Green	Y

E W 24 B 00 G L Y

LCD type + LCD color	Code Value
STN + Yellow-Green	Y
STN + Gray	G
STN + Blue	B
FSTN + White	F
FSTN + Black	N

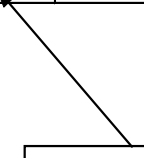
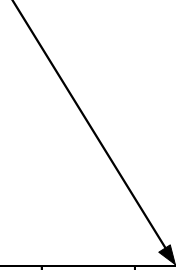

TABLE OF CONTENTS

NO.	ITEM	PAGE
=====		
1.	GENERAL SPECIFICATIONS -----	1
2.	MECHANICAL SPECIFICATIONS -----	1
3.	ABSOLUTE MAXIMUM RATINGS -----	2
4.	ELECTRICAL CHARACTERISTICS -----	3
5.	OPTICAL CHARACTERISTICS -----	4
6.	OUTLINE DIMENSION -----	5
7.	DETAIL DRAWING OF DOT MATRIX -----	6
8.	BLOCK DIAGRAM -----	6
9.	INTERFACE SIGNALS -----	7
10.	POWER SUPPLY -----	8

1. GENERAL SPECIFICATIONS

1.1 QUALITY SPECIFICATIONS
PLEASE REFER TO :

CUSTOMER ACCEPTANCE STANDARD SPECIFICATIONS :

E U - 0 0 2 A

1.2 APPLICATION NOTES FOR CONTROLLER / DRIVER :
PLEASE REFER TO :

CUSTOMER ACCEPTANCE STANDARD SPECIFICATIONS :

E U - T 6 9 6 3 C

1.3 THIS INDIVIDUAL SPECIFICATIONS IS PRIOR TO GENERAL
SPECIFICATIONS .

2. MECHANICAL SPECIFICATIONS

- (1) NUMBER OF DOTS ----- 240W * 64H DOTS
- (2) MODULE SIZE ----- 180.0W * 65.0H * 16.0D (max .) mm
- (3) EFFECTIVE AREA ----- 133.0W * 40.0H mm
- (4) ACTIVE AREA ----- 127.16W * 33.88H mm
- (5) DOT SIZE ----- 0.49W * 0.49H mm
- (6) DOT PITCH ----- 0.53W * 0.53H mm
- (7) LCD TYPE *
- (8) DRIVING METHOD ----- 1 / 64 DUTY MULTIPLEX DRIVE
- (9) BACK LIGHT ----- LED, COLOR : YELLOW-GREEN

* PLEASE REFER TO NUMBERING SYSTEM

3. ABSOLUTE MAXIMUM RATINGS

3.1 ELECTRICAL ABSOLUTE MAXIMUM RATINGS . (AT Ta = 25 °C)

PARAMETER	SYMBOL	MIN .	MAX .	UNIT	REMARK
POWER SUPPLY FOR LOGIC	VDD - VSS	0	7.0	V	
POWER SUPPLY FOR LCD DRIVE	VDD - VEE	0	22.0	V	
INPUT VOLTAGE	VI	VSS	VDD	V	
STATIC ELECTRICITY	—	—	100	V	NOTE (1)
LED POWER DISSIPATION	PD	—	7.4	W	
LED FORWARD CURRENT	IF	—	1625	mA	
LED REVERSE VOLTAGE	VR	—	8	V	

NOTE (1) : TEST METHOD AND CONDITIONS :
 AFTER CHARGING UP 200 PF CAPACITOR BY STATED VOLTAGE ,
 THE CAPACITOR IS CONNECTED WITH INTERFACE PINS OF THE
 MODULE .

3.2 ENVIRONMENTAL ABSOLUTE MAXIMUM RATINGS .

I T E M	OPERATING		STORAGE		REMARK
	MIN .	MAX .	MIN .	MAX .	
AMBIENT TEMPERATURE	- 20 °C	70 °C	- 30 °C	80 °C	NOTE (2), (3)
HUMIDITY	—	85 % RH	—	85 % RH	WITHOUT CONDENSATION
VIBRATION	—	4.9 m/s ² (0.5 G)	—	19.6 m/s ² (2 G)	10~300 HZ XYZ DIRECTIONS 1 Hr EACH
SHOCK	—	29.4 m/s ² (3 G)	—	490.0 m/s ² (50 G)	10 m SEC XYZ DIRECTIONS 1 TIME EACH
CORROSIVE GAS	NOT ACCEPTABLE		NOT ACCEPTABLE		

NOTE (2) : Ta AT -30°C: 48HR MAX .
 80°C: 168HR MAX .

NOTE (3) : BACKGROUND COLOR CHANGES SLIGHTLY DEPENDING ON AMBIENT
 TEMPERATURE THIS PHENOMENON IS REVERSIBLE .

4. ELECTRICAL CHARACTERISTICS

PARAMETER	SYMBOL	CONDITION	MIN .	TYP .	MAX .	UNIT
POWER SUPPLY VOLTAGE FOR LOGIC	VDD-VSS	—	4.75	5.0	5.25	V
POWER SUPPLY VOLTAGE FOR LCD DRIVE	VEE-VSS	—	-2.0	—	-10.0	V
INPUT VOLTAGE NOTE (1)	V _{IH}	H LEVEL	VDD-2.2	—	VDD	V
	V _{IL}	L LEVEL	0	—	0.8	V
OUTPUT VOLTAGE NOTE (1)	V _{OH}	H LEVEL	VDD-0.3	—	VDD	
	V _{OL}	L LEVEL	0	—	0.3	
POWER SUPPLY CURRENT FOR LOGIC NOTE (2)	IDD	VDD - VSS = 5.0 V VDD - VEE = 8.7 V	—	9.0	—	mA
RECOMMENDED LCD DRIVING VOLTAGE NOTE (3)	VDD-VEE ∅ = 10° θ = 0° DUTY=1/64	T _a = -20 °C	—	8.7	—	V
		T _a = 25 °C	—	8.7	—	V
		T _a = 70 °C	—	7.9	—	V
CLOCK OSCILLATION FREQUENCY	f _{OSC}	—	—	3.58	—	MHZ
LED FORWARD VOLTAGE	V _F	I _F = 650 mA	—	4.2	4.6	V
LED FORWARD CURRENT	I _F	—	—	650	—	mA
LED REVERSE CURRENT	I _R	V _R = 8 V	—	—	200	μA

NOTE (1): APPLIED TO TERMINALS (WR, RD, CE, C/D, RST, FS, D0~D7)

NOTE (2): THE DISPLAY PATTERN IS ALL "OFF"/"ON"

NOTE (3): RECOMMENDED LCD DRIVING VOLTAGE MAY FLUCTUATE ABOUT ± 0.5 V BY EACH MODULE

5. OPTICAL CHARACTERISTICS

Ta = 25 °C

VDD = 5.0 V

I T E M		SYMBOL	CONDITION	MIN .	TYP .	MAX.	UNIT	NOTE
VIEWING AREA	STN	∅ 2 - ∅ 1	K ≥ 1.4	40	—	—	deg.	1
	FSTN			50	—	—	deg.	1
CONTRAST RATIO	STN	K	∅ = 10° θ = 0°	—	5	—	—	1
	FSTN			5	—	—	—	1
RESPONSE TIME	tr (rise)	∅ = 10° θ = 0°	Ta = -20°C	—	3982	—	ms	1
			Ta = 25°C	—	228	—		
			Ta = 70°C	—	83	—		
	tf (fall)		Ta = -20°C	—	3752	—		
			Ta = 25°C	—	176	—		
			Ta = 70°C	—	94	—		
THE BRIGHTNESS OF BACK-LIGHT	L	IF = 650 mA	—	30	—	—	cd/m ²	1, 2
				65				1, 3
PEAK EMISSION WAVELENGTH	λP	IF = 650 mA	—	572	—	—	nm	1

NOTE (1) : PLEASE REFER TO :
 CUSTOMER ACCEPTANCE STANDARD SPECIFICATIONS.
 E U - 0 0 2 A

NOTE (2) : POLARIZER MODE : TRANSFLECTIVE

NOTE (3) : POLARIZER MODE : TRANSMISSIVE

MODEL NO.	VERSION	PAGE
24B00(LED TYPES)	4	5

6. OUTLINE DIMENSION

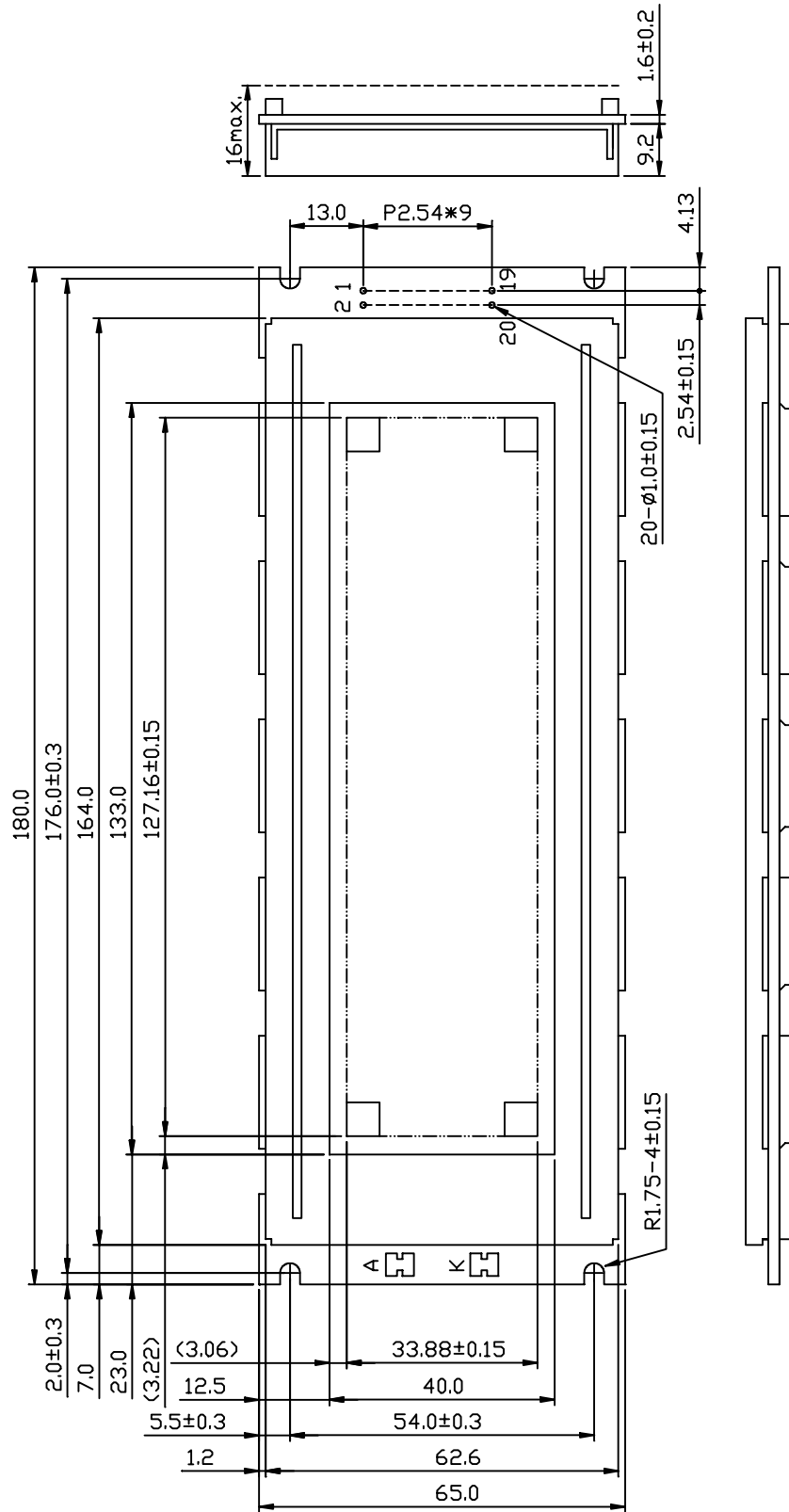

UNIT : mm
 SCALE : NTS
 NOT SPECIFIED TOLERANCE IS ± 0.5

7. DETAIL DRAWING OF DOT MATRIX

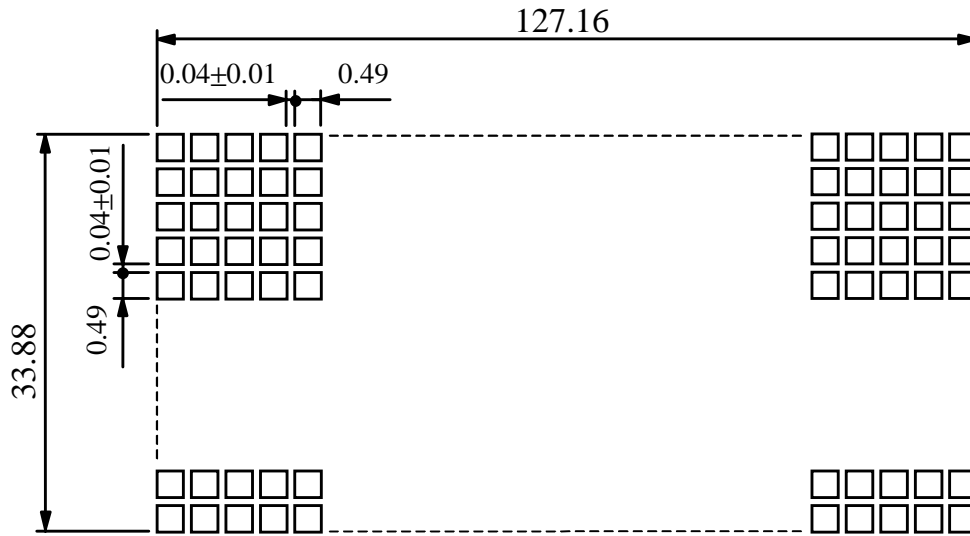

UNIT : mm
SCALE : NTS
NOT SPECIFIED TOLERANCE IS ± 0.1

8. BLOCK DIAGRAM

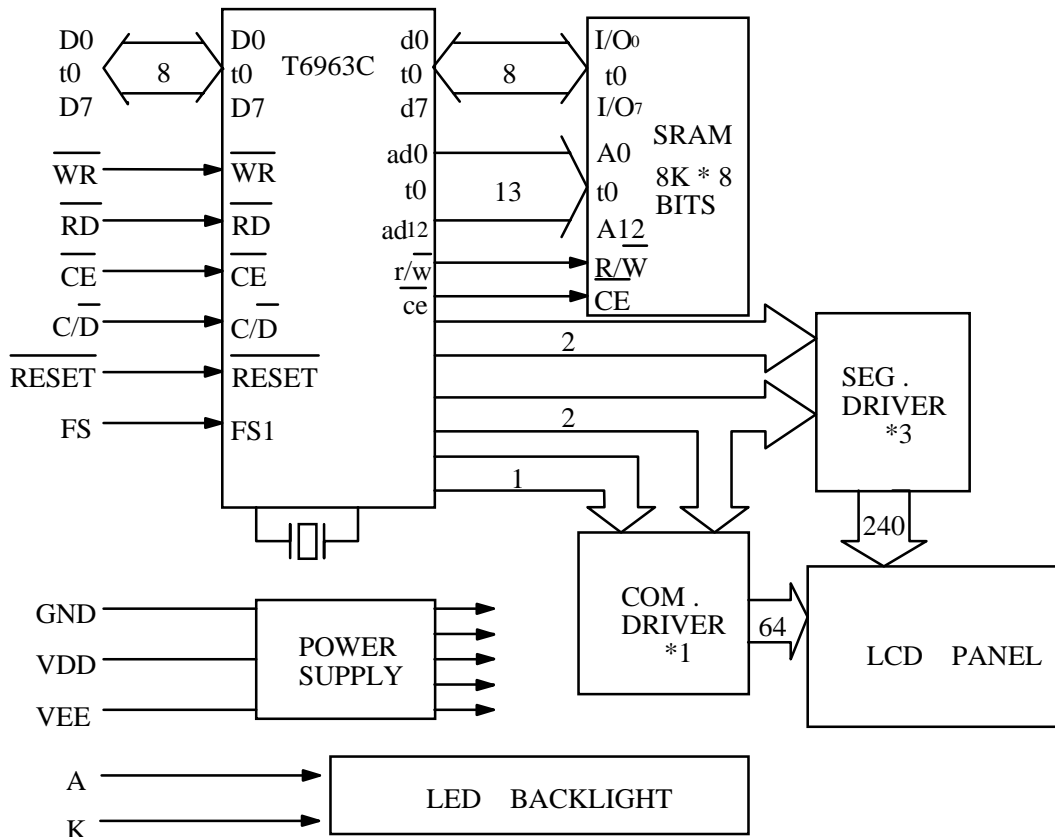

9. INTERFACE SIGNALS

PIN NO .	SIGNAL	FUNCTION
1	FGND	FRAME GROUND (0V)
2	GND	GROUND
3	VDD	POWER SUPPLY FOR LOGIC (+5V)
4	VEE	POWER SUPPLY FOR LCD DRIVER
5	$\overline{\text{WR}}$	DATA WRITE
6	$\overline{\text{RD}}$	DATA READ
7	$\overline{\text{CE}}$	CHIP ENABLE
8	C/D	$\overline{\text{WR}} = "L", \overline{\text{C/D}} = "H" : \text{COMMAND WRITE}$ $\overline{\text{C/D}} = "L" : \text{DATA WRITE}$ $\text{RD} = "L", \text{C/D} = "H" : \text{STATUS READ}$ $\text{C/D} = "L" : \text{DATA READ}$
9	NC	—————
10	$\overline{\text{RESET}}$	CONTROLLER RESET
11~18	D0~D7	DATA INPUT/OUTPUT
19	FS	FONT SELECT : CONNECT TO VDD : 6*8 PIXEL/FONT CONNECT TO GND : 8*8 PIXEL/FONT
20	NC	—————
A	VLED	POWER SUPPLY FOR LED BACKLIGHT (ANODE)
K	VLSS	POWER SUPPLY FOR LED BACKLIGHT (CATHODE)

10. POWER SUPPLY

10.1 POWER SUPPLY FOR LCD MODULE

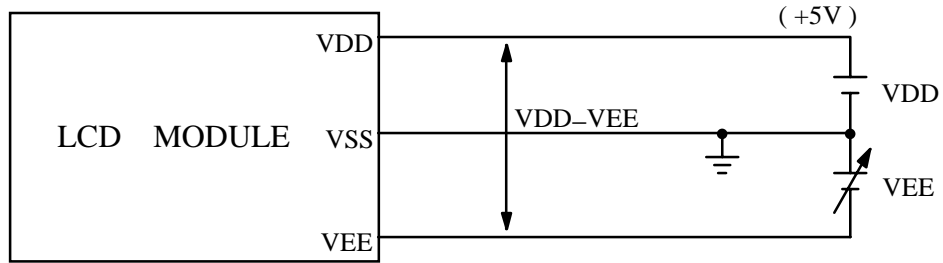

VDD-VEE : LCD DRIVING VOLTAGE

10.2 POWER SUPPLY FOR LED BACK-LIGHT

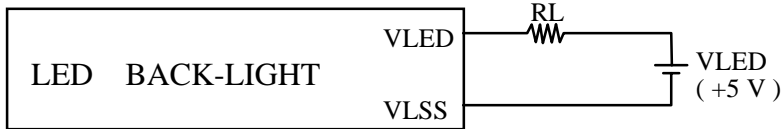

RECOMMENDED RESISTOR R_L : 1.2~2.5 Ω , 1 WATT (CONTROLLED BY USER)
 * THE BRIGHTNESS WOULD BE ALTERED SUBJECT TO DIFFERENT VALUES OF R_L

10.3 POWER AND INTERFACE TIMING SEQUENCE

