

EXAMINED BY:  <i>Jony Chen</i>	<b>MITSUTECH</b>  INTERNATIONAL CORPORATION	FILE NO . CAS-10020
APPROVED BY:  <i>David Chang</i>		ISSUE : NOV.10,1999
		TOTAL PAGE : 9
		VERSION : 2

CUSTOMER	ACCEPTANCE	SPECIFICATIONS
----------	------------	----------------

MODEL NO . :

24D00(REFLECTIVE TYPES)

FOR MESSRS :

\_\_\_\_\_

CUSTOMER'S APPROVAL

DATE :

\_\_\_\_\_

BY :

\_\_\_\_\_



MODEL NO.	VERSION
24D00(REFLECTIVE TYPES)	2

NUMBERING SYSTEM

Polarizer Mode	Backlight	Code value
Reflective	—	R

E W 2 4 D 0 0 G R

LCD type + color	Code Value
STN + Yellow-Green	Y
STN + Gray	G
FSTN + White	F

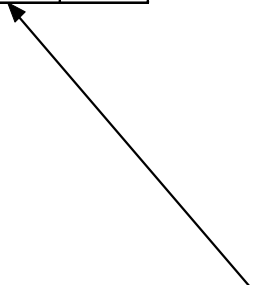
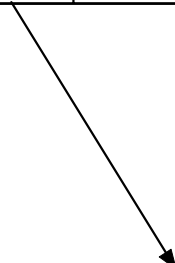

MODEL NO.	VERSION
24D00(REFLECTIVE TYPES)	2

TABLE OF CONTENTS

NO.	ITEM	PAGE
=====		
1.	GENERAL SPECIFICATIONS -----	1
2.	MECHANICAL SPECIFICATIONS -----	1
3.	ABSOLUTE MAXIMUM RATINGS -----	2
4.	ELECTRICAL CHARACTERISTICS -----	3
5.	INTERFACE TIMING CHARACTERISTICS -----	4
6.	OPTICAL CHARACTERISTICS -----	5
7.	OUTLINE DIMENSION -----	6
8.	BLOCK DIAGRAM -----	7
9.	DETAIL DRAWING OF DOT MATRIX -----	8
10.	INTERFACE SIGNALS -----	8
11.	POWER SUPPLY -----	9

MODEL NO.	VERSION	PAGE
24D00(REFLECTIVE TYPES)	2	1

1. GENERAL SPECIFICATIONS

1.1 GENERAL SPECIFICATIONS

PLEASE REFER TO :

CUSTOMER ACCEPTANCE STANDARD SPECIFICATIONS :

E U - 0 0 2 A

1.2 APPLICATION NOTES FOR CONTROLLER

PLEASE REFER TO :

CUSTOMER ACCEPTANCE STANDARD SPECIFICATIONS :

E U - 1 1 0

1.3 THIS INDIVIDUAL SPECIFICATION IS PRIOR TO GENERAL SPECIFICATIONS .

2. MECHANICAL SPECIFICATIONS

- (1) NUMBER OF DOTS ----- 240W \* 128H DOTS
- (2) MODULE SIZE ----- 144.0W \* 104.0H \* 10.3D (max.) mm
- (3) EFFECTIVE AREA ----- 114.0W \* 64.0H mm
- (4) ACTIVE AREA ----- 107.97W \* 57.57H mm
- (5) DOT SIZE ----- 0.42W \* 0.42H mm
- (6) DOT PITCH ----- 0.45W \* 0.45H mm
- (7) LCD TYPE \*
- (8) DRIVING METHOD ----- 1 / 128 DUTY MULTIPLEX DRIVE

\* PLEASE REFER TO NUMBERING SYSTEM .

### 3. ABSOLUTE MAXIMUM RATINGS

#### 3.1 ELECTRICAL ABSOLUTE MAXIMUM RATINGS.

PARAMETER	SYMBOL	MIN.	MAX.	UNIT	REMARK
POWER SUPPLY FOR LOGIC	VDD - VSS	0	6.5	V	
POWER SUPPLY FOR LCD DRIVING	VDD - VEE	0	22.0	V	
INPUT VOLTAGE	VI	VSS	VDD	V	
STATIC ELECTRICITY	—	—	100	V	NOTE (1)

NOTE (1) : TEST METHOD AND CONDITIONS :  
 AFTER CHARGING UP 200 PF CAPACITOR BY STATED VOLTAGE ,  
 THE CAPACITOR IS CONNECTED WITH INTERFACE PINS OF THE  
 MODULE .

#### 3.2 ENVIRONMENTAL ABSOLUTE MAXIMUM RATINGS .

I T E M	OPERATING		STORAGE		REMARK
	MIN.	MAX.	MIN.	MAX.	
AMBIENT TEMPERATURE	-20 °C	70 °C	-30 °C	80 °C	NOTE (2) , (3)
HUMIDITY	—	85 % RH	—	85 % RH	WITHOUT CONDENSATION
VIBRATION	—	2.45 m/s <sup>2</sup> (0.25 G)	—	11.76 m/s <sup>2</sup> (1.2 G)	10~100 HZ XYZ DIRECTIONS 1 Hr . EACH
SHOCK	—	29.4 m/s <sup>2</sup> (3 G)	—	490.0 m/s <sup>2</sup> (50 G)	10 mSECONDS XYZ DIRECTIONS 1 TIME EACH
CORROSIVE GAS	NOT ACCEPTABLE		NOT ACCEPTABLE		

NOTE (2) : Ta AT -30°C : 48HR MAX .  
 80°C : 168HR MAX .

NOTE (3) : BACKGROUND COLOR CHANGES SLIGHTLY DEPENDING ON AMBIENT  
 TEMPERATURE THIS PHENOMENON IS REVERSIBLE .

## 4. ELECTRICAL CHARACTERISTICS

Ta = 25 °C

VDD = 5.0 V

PARAMETER	SYMBOL	CONDITION	MIN .	TYP .	MAX .	UNIT
POWER SUPPLY VOLTAGE FOR LOGIC	VDD - VSS	—	4.75	5.0	5.25	V
POWER SUPPLY VOLTAGE FOR LCD DRIVE	VEE - VSS	—	-15.5	-16.0	-16.5	V
INPUT VOLTAGE NOTE (1)	VIH	H LEVEL	2.2	—	—	V
	VIL	L LEVEL	—	—	0.8	V
OUTPUT VOLTAGE NOTE (2)	VOH	H LEVEL	2.4	—	VCC	V
	VOL	L LEVEL	0	—	0.4	V
POWER SUPPLY CURRENT FOR LOGIC NOTE (2)	IDD	VDD-VSS = 5.0 V VDD-VO = 18.2V	—	6.0	—	mA
POWER SUPPLY CURRENT FOR LCD DRIVE NOTE (2)	IEE	VDD-VSS = 5.0 V VDD-VO = 18.2V	—	5.0	—	mA
RECOMMENDED LCD DRIVING VOLTAGE NOTE (3)	VDD - VO ∅ = 10° θ = 0°	Ta = -20 °C	—	18.2	—	V
		Ta = 25 °C	—	18.2	—	
		Ta = 70 °C	—	15.0	—	
CLOCK OSCILLATION FREQUENCY	f osc	—	—	2	—	MHZ

NOTE (1): APPLIED TO TERMINALS  $\overline{E}$ ,  $\overline{CS}$ ,  $\overline{R/W}$ , RS, DB0~DB7,  $\overline{RES}$ .

NOTE (2): THE DISPLAY PATTERN IS ALL "OFF" / "ON".

NOTE (3): RECOMMENDED LCD DRIVING VOLTAGE MAY FLUCTUATE ABOUT ±1.0V BY EACH MODULE.

5. INTERFACE TIMING CHARACTERISTICS

V<sub>CC</sub> = 5.0 V, T<sub>a</sub> = -20 ~ 70 °C

ITEM	SYMBOL	MIN	TYP	MAX	UNIT
Enable cycle time	t <sub>CYC</sub>	1.0	—	—	μs
Enable pulse width	H LEVEL	t <sub>WEH</sub>	0.45	—	μs
	L LEVEL	t <sub>WEL</sub>	0.45	—	μs
Enable rise time	t <sub>Er</sub>	—	—	25	ns
Enable fall time	t <sub>Ef</sub>	—	—	25	ns
Setup time	t <sub>AS</sub>	140	—	—	ns
Data setup time	t <sub>DSW</sub>	225	—	—	ns
Data delay time	t <sub>DDR</sub>	—	—	225	ns
Data hold time	t <sub>DHW</sub>	10	—	—	ns
Address hold time	t <sub>AH</sub>	10	—	—	ns
Data hold time	t <sub>DH</sub>	20	—	—	ns

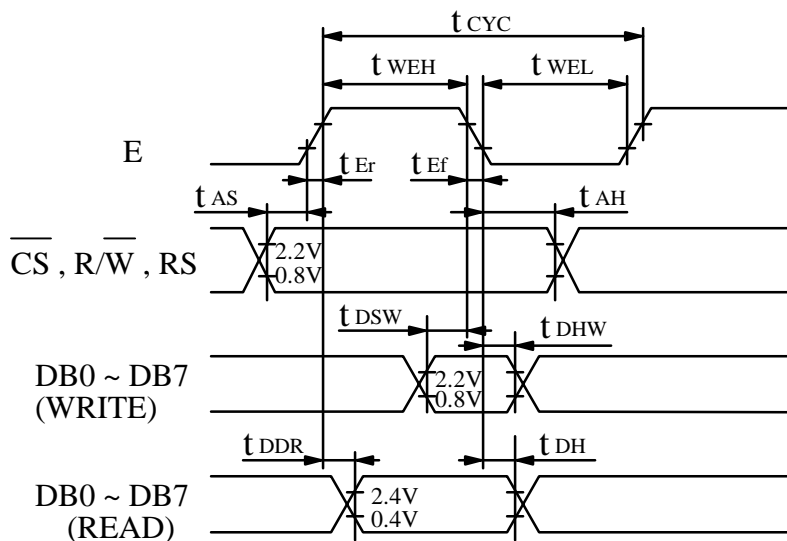

6. OPTICAL CHARACTERISTICS

Ta = 25°C		VDD = 5.0 V		VDD - VO = 18.2 V				
I T E M		SYMBOL	CONDITION	MIN.	TYP.	MAX.	UNIT	NOTE
VIEWING AREA	STN	Ø2 -Ø1	K ≥ 1.4	40	—	—	deg.	1
	FSTN			50	—	—	deg.	1
CONTRAST RATIO	STN	K	Ø = 10° θ = 0°	—	5	—	—	1
	FSTN			5	—	—	—	1
RESPONSE TIME	tr ( rise )	Ø = 10° θ = 0°	Ta = -20°C	—	2886	—	ms	1
			Ta = 25°C	—	259	—		
			Ta = 70°C	—	156	—		
	tf ( fall )		Ta = -20°C	—	2193	—		
			Ta = 25°C	—	177	—		
			Ta = 70°C	—	84	—		

NOTE (1) : PLEASE REFER TO :  
 CUSTOMER ACCEPTANCE STANDARD SPECIFICATIONS.  
 E U - 002 A

MODEL NO.	VERSION	PAGE
24D00(REFLECTIVE TYPES)	2	6

7. OUTLINE DIMENSION

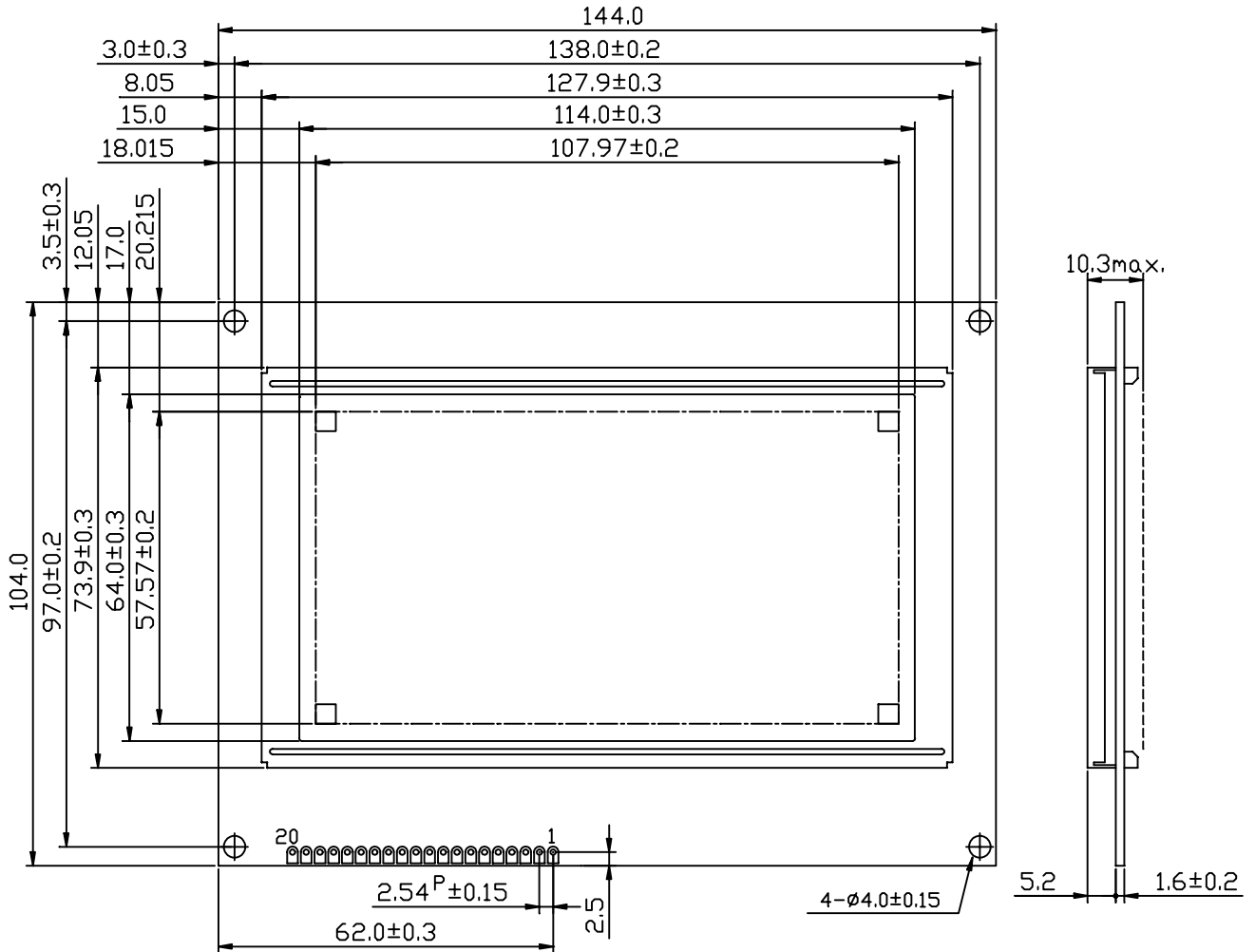

UNIT : mm  
 SCALE : NTS  
 NOT SPECIFIED TOLERANCE IS ± 0.5

8. BLOCK DIAGRAM

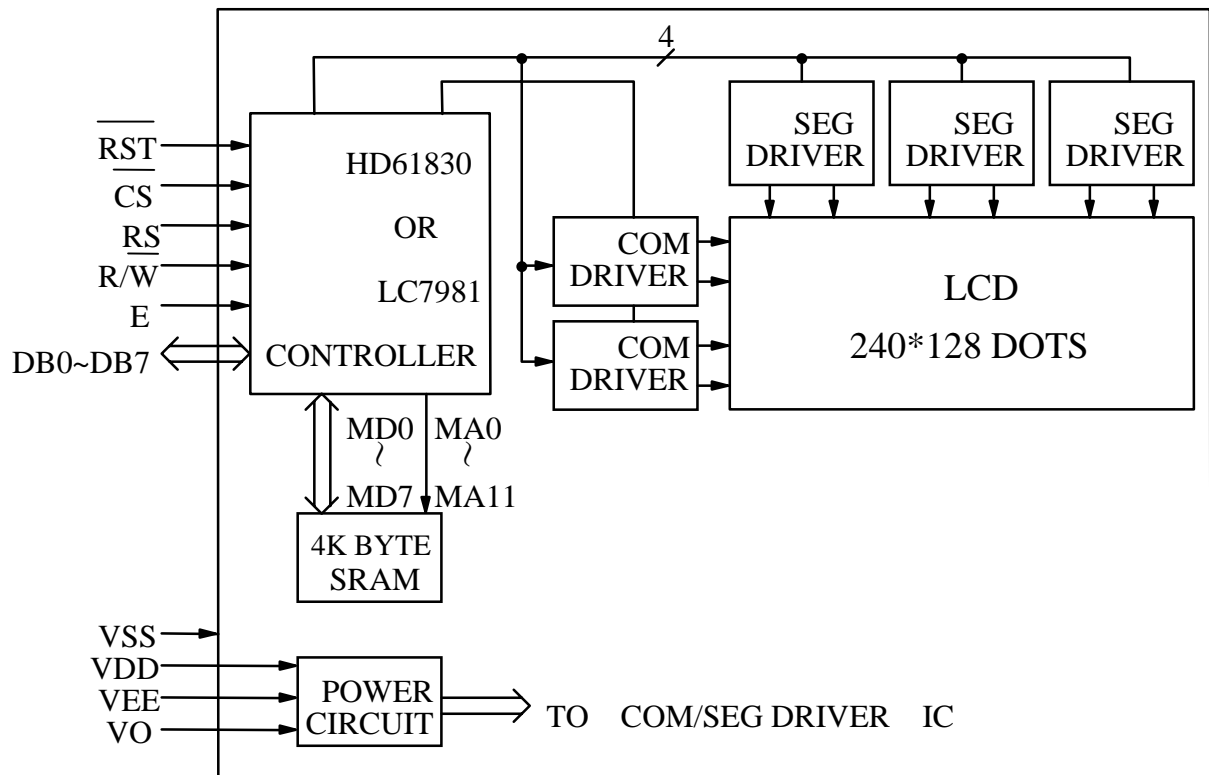

9. DETAIL DRAWING OF DOT MATRIX

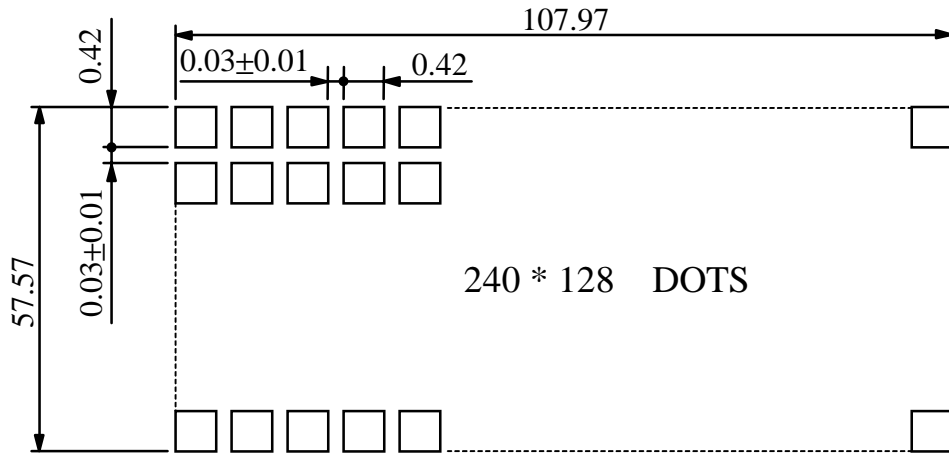

UNIT : mm  
 SCALE : NTS  
 NOT SPECIFIED TOLERANCE IS ± 0.1

10. INTERFACE SIGNALS

PIN NO	SYMBOL	LEVEL	FUNCTION
1	VSS	—	GROUND
2	VDD	—	POWER SUPPLY FOR LOGIC CIRCUIT
3	V0	—	OPERATING VOLTAGE FOR LCD DRIVE
4	RS	H/L	H : INSTRUCTION REGISTER L : DATA REGISTER
5	R/W	H/L	H : DATA READ (LCD MODULE → MPU) L : DATA WRITE (LCD MODULE ← MPU)
6	E	H,H→L	ENABLE SIGNAL
7   14	DB0   DB7	H/L	DATA BUS LINE
15	CS	H→L	CHIP SELECTION
16	RST	L	RESET
17	VEE	—	POWER SUPPLY FOR LCD DRIVE
18   20	N.C	—	—————

1 1 . POWER SUPPLY

1 1 . 1 POWER SUPPLY FOR LCM

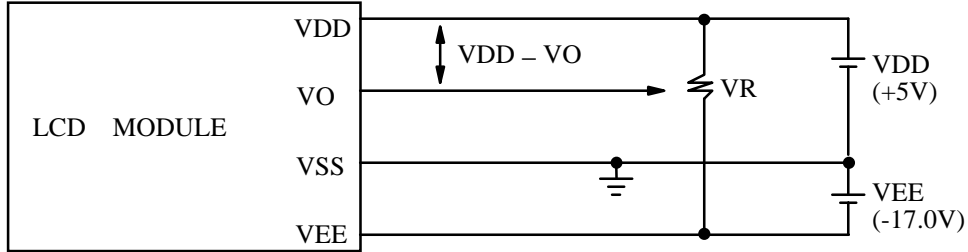

VDD - VO : LCD DRIVING VOLTAGE  
 VR: 20K $\Omega$

1 1 . 2 TIMING OF POWER SUPPLY AND INTERFACE SIGNAL

