

EXAMINED BY : <i>Jony Chen</i>	<p style="text-align: center;">MITSUTECH</p> <p style="text-align: center;">INTERNATIONAL CORPORATION</p>	FILE NO . CAS-10021
APPROVED BY: <i>David Chang</i>		ISSUE : NOV.10,1999
		TOTAL PAGE : 8
		VERSION : 2

CUSTOMER	ACCEPTANCE	SPECIFICATIONS
----------	------------	----------------

MODEL NO. :

24D30(REFLECTIVE TYPES)

FOR MESSRS :

CUSTOMER'S APPROVAL

DATE :

BY :

MODEL NO.	VERSION
24D30(REFLECTIVE TYPES)	2

NUMBERING SYSTEM

Polarizer Mode	Backlight	Code value
Reflective	—	R

E W 2 4 D 3 0 G R

LCD type + color	Code Value
STN + Yellow-Green	Y
STN + Gray	G
FSTN + White	F

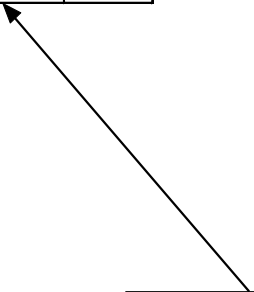
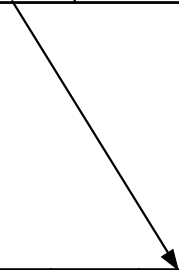

TABLE OF CONTENTS

NO.	ITEM	PAGE
=====		
1.	GENERAL SPECIFICATIONS -----	1
2.	MECHANICAL SPECIFICATIONS -----	1
3.	ABSOLUTE MAXIMUM RATINGS -----	2
4.	ELECTRICAL CHARACTERISTICS -----	3
5.	OPTICAL CHARACTERISTICS -----	4
6.	OUTLINE DIMENSION -----	5
7.	BLOCK DIAGRAM -----	6
8.	DETAIL DRAWING OF DOT MATRIX -----	7
9.	INTERFACE SIGNALS -----	7
10.	POWER SUPPLY -----	8

MODEL NO.	VERSION	PAGE
24D30(REFLECTIVE TYPES)	2	1

1. GENERAL SPECIFICATIONS

1.1 GENERAL SPECIFICATIONS

PLEASE REFER TO :

CUSTOMER ACCEPTANCE STANDARD SPECIFICATIONS :

E U - 0 0 2 A

1.2 APPLICATION NOTES FOR CONTROLLER : T6963C

PLEASE REFER TO :

CUSTOMER ACCEPTANCE STANDARD SPECIFICATIONS :

E U - T 6 9 6 3 C

1.3 THIS INDIVIDUAL SPECIFICATION IS PRIOR TO GENERAL SPECIFICATIONS .

2. MECHANICAL SPECIFICATIONS

- (1) NUMBER OF DOTS ----- 240W * 128H DOTS
- (2) MODULE SIZE ----- 144.0W * 104.0H * 11.0D mm
- (3) EFFECTIVE AREA ----- 114.0W * 64.0H mm
- (4) ACTIVE AREA ----- 107.97W * 57.57H mm
- (5) DOT SIZE ----- 0.42W * 0.42H mm
- (6) DOT PITCH ----- 0.45W * 0.45H mm
- (7) LCD TYPE *
- (8) DRIVING METHOD ----- 1 / 128 DUTY MULTIPLEX DRIVE

* PLEASE REFER TO NUMBERING SYSTEM .

3. ABSOLUTE MAXIMUM RATINGS

3.1 ELECTRICAL ABSOLUTE MAXIMUM RATINGS.

PARAMETER	SYMBOL	MIN.	MAX.	UNIT	REMARK
POWER SUPPLY FOR LOGIC	VDD — VSS	0	6.5	V	
POWER SUPPLY FOR LCD DRIVING	VDD — VEE	0	22.0	V	
INPUT VOLTAGE	VI	VSS	VDD	V	
STATIC ELECTRICITY	—	—	100	V	NOTE (1)

NOTE (1) : TEST METHOD AND CONDITIONS :
 AFTER CHARGING UP 200 PF CAPACITOR BY STATED VOLTAGE ,
 THE CAPACITOR IS CONNECTED WITH INTERFACE PINS OF THE
 MODULE .

3.2 ENVIRONMENTAL ABSOLUTE MAXIMUM RATINGS .

I T E M	OPERATING		STORAGE		REMARK
	MIN.	MAX.	MIN.	MAX.	
AMBIENT TEMPERATURE	-20 °C	70 °C	-30 °C	80 °C	NOTE (2), (3)
HUMIDITY	—	85 % RH	—	85 % RH	WITHOUT CONDENSATION
VIBRATION	—	2.45 m/s ² (0.25 G)	—	11.76 m/s ² (1.2 G)	10~100 HZ XYZ DIRECTIONS 1 Hr. EACH
SHOCK	—	29.4 m/s ² (3 G)	—	490.0 m/s ² (50 G)	10 mSECONDS XYZ DIRECTIONS 1 TIME EACH
CORROSIVE GAS	NOT ACCEPTABLE		NOT ACCEPTABLE		

NOTE (2) : Ta AT -30°C : 48HR MAX.
 80°C : 168HR MAX.

NOTE (3) : BACKGROUND COLOR CHANGES SLIGHTLY DEPENDING ON AMBIENT
 TEMPERATURE THIS PHENOMENON IS REVERSIBLE .

4. ELECTRICAL CHARACTERISTICS

Ta = 25 °C

VDD = 5.0 V

PARAMETER	SYMBOL	CONDITION	MIN .	TYP .	MAX .	UNIT
POWER SUPPLY VOLTAGE FOR LOGIC	VDD — VSS	—	4.75	5.0	5.25	V
POWER SUPPLY VOLTAGE FOR LCD DRIVE	VEE — VSS	—	- 15.5	- 16.0	- 16.5	V
INPUT VOLTAGE NOTE (1)	VIH	H LEVEL	2.2	—	—	V
	VIL	L LEVEL	—	—	0.8	V
OUTPUT VOLTAGE NOTE (1)	VOH	H LEVEL	2.4	—	VCC	V
	VOL	L LEVEL	0	—	0.4	V
POWER SUPPLY CURRENT FOR LOGIC NOTE (2)	IDD	VDD-VSS = 5.0 V VDD-VO = 18.2V	—	6.0	—	mA
POWER SUPPLY CURRENT FOR LCD DRIVE NOTE (2)	IEE	VDD-VSS = 5.0 V VDD-VO = 18.2V	—	5.0	—	mA
RECOMMENDED LCD DRIVING VOLTAGE NOTE (3)	VDD-V0 ∅ = 10° θ = 0°	Ta = - 20 °C	—	18.2	—	V
		Ta = 25 °C	—	18.2	—	
		Ta = 70 °C	—	15.0	—	
CLOCK OSCILLATION FREQUENCY	f _{osc}	—	—	6	—	MHZ

NOTE (1): APPLIED TO TERMINALS FS, CE, \overline{WR} , \overline{RD} , C/D, DB0~DB7, \overline{RES} , MD2.

NOTE (2): THE DISPLAY PATTERN IS ALL "OFF" / "ON".

NOTE (3): RECOMMENDED LCD DRIVING VOLTAGE MAY FLUCTUATE ABOUT ± 1.0V BY EACH MODULE.

5. OPTICAL CHARACTERISTICS

Ta = 25 °C

VDD = 5.0 V

VDD-V0 = 18.2 V

I T E M		SYMBOL	CONDITION	MIN.	TYP.	MAX.	UNIT	NOTE
VIEWING AREA	STN	Ø2 - Ø1	K ≥ 1.4	40	—	—	deg.	1
	FSTN			50	—	—	deg.	1
CONTRAST RATIO	STN	K	Ø = 10° θ = 0°	—	5	—	—	1
	FSTN			5	—	—	—	1
RESPONSE TIME	tr (rise)	Ø = 10° θ = 0°	Ta = -20°C	—	2886	—	ms	1
			Ta = 25°C	—	259	—		
			Ta = 70°C	—	156	—		
	tf (fall)		Ta = -20°C	—	2193	—		
			Ta = 25°C	—	177	—		
			Ta = 70°C	—	84	—		

NOTE (1) : PLEASE REFER TO :
 CUSTOMER ACCEPTANCE STANDARD SPECIFICATIONS.
 E U - 0 0 2 A

6. OUTLINE DIMENSION

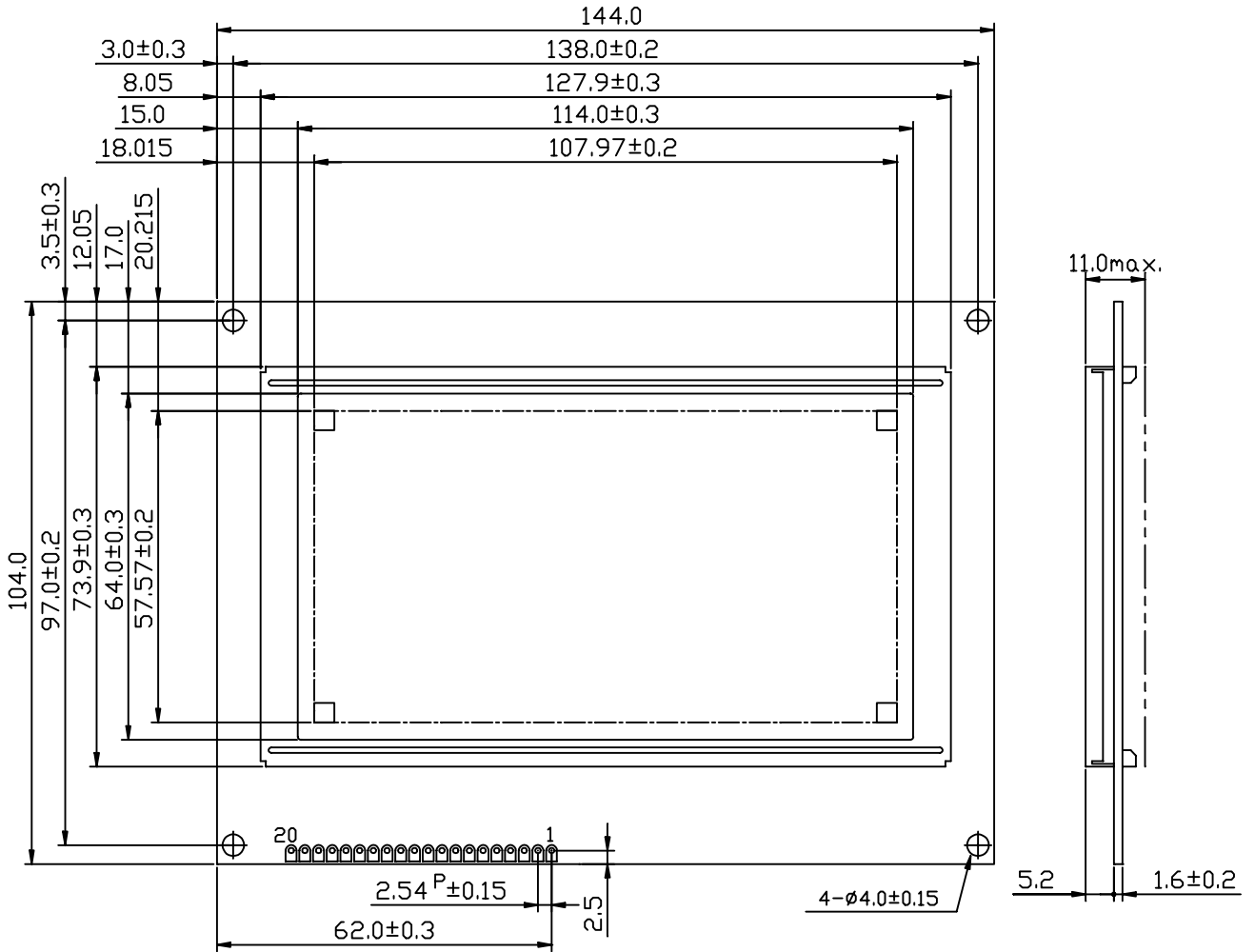

UNIT : mm
 SCALE : NTS
 NOT SPECIFIED TOLERANCE IS ± 0.5

7. BLOCK DIAGRAM

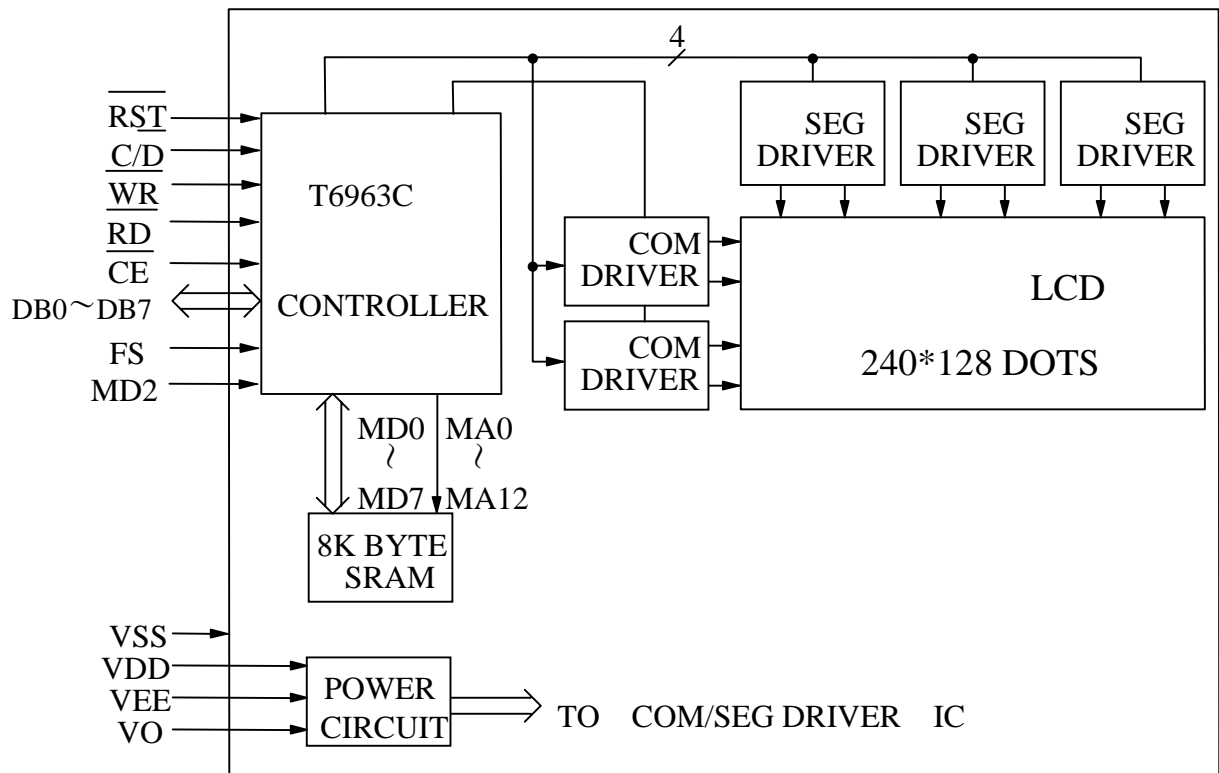

8. DETAIL DRAWING OF DOT MATRIX

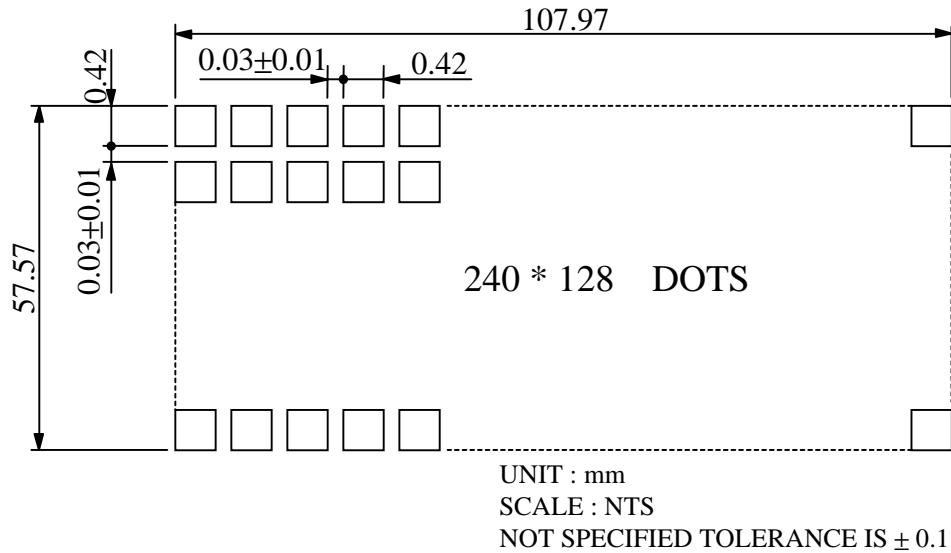

9. INTERFACE SIGNALS

PIN NO	SYMBOL	LEVEL	FUNCTION
1	VSS	—	GROUND
2	VDD	—	POWER SUPPLY FOR LOGIC CIRCUIT
3	V0	—	OPERATING VOLTAGE FOR LCD DRIVE
4	C/D	H/L	\overline{WR} = "L", $\overline{C/D}$ = "H" : COMMAND WRITE $\overline{C/D}$ = "L" : DATA WRITE \overline{RD} = "L", $\overline{C/D}$ = "H" : STATUS READ $\overline{C/D}$ = "L" : DATA READ
5	\overline{RD}	L	DATA READ
6	\overline{WR}	L	DATA WRITE
7 14	DB0 DB7	H/L	DATA BUS LINE
15	\overline{CE}	L	CHIP SELECTION
16	\overline{RST}	L	RESET
17	VEE	—	POWER SUPPLY FOR LCD DRIVE
18	MD2	H/L	COLUMNS SELECT : "H" : 32 COLUMNS "L" : 40 COLUMNS
19	FS	H/L	SELECT : "H" : 6*8 PIXEL/FONT "L" : 8*8 PIXEL/FONT
20	N.C	—	—

10. POWER SUPPLY

10.1 POWER SUPPLY FOR LCM

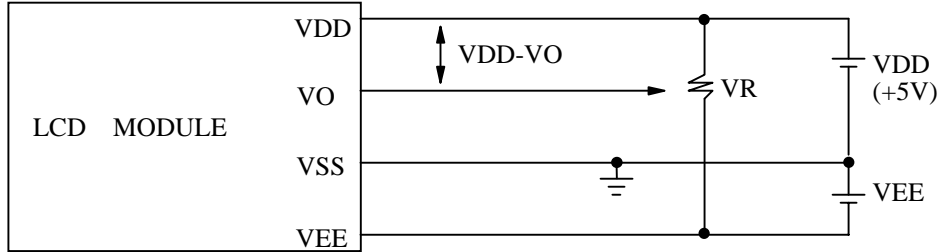

VDD-V0 : LCD DRIVING VOLTAGE
 VR : 20K Ω

10.2 TIMING OF POWER SUPPLY AND INTERFACE SIGNAL

