

EXAMINED BY: <i>Jony Chen</i>	mitsutech INTERNATIONAL CORPORATION	FILE NO . CAS-10145
APPROVED BY: <i>David Chang</i>		ISSUE : NOV.11,1999
		TOTAL PAGE : 8
		VERSION : 2

CUSTOMER ACCEPTANCE SPECIFICATIONS

MODEL NO. :

24D70 (CCFL TYPES)

FOR MESSRS :

CUSTOMER'S APPROVAL

DATE :

BY :

MODEL NO. 24D70 (CCFL TYPES)	VERSION 2
-----------------------------------	--------------

NUMBERING SYSTEM

Polarizer Mode	Backlight	Code value
Transflective	CCFL	D
Transmissive	CCFL	C

Backlight Color	Code Value
White	W

E	W	24	D	70	N	C	W
---	---	----	---	----	---	---	---

LCD type + color	Code Value
STN + Gray	G
STN + Blue	B
FSTN + White	F
FSTN + Black	N

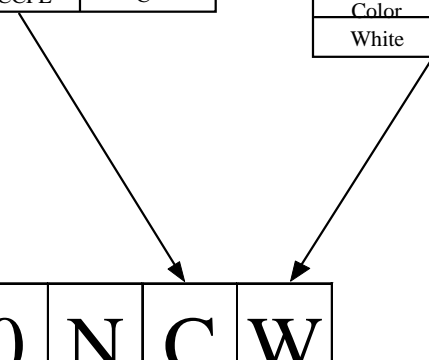

TABLE OF CONTENTS

NO.	ITEM	PAGE
1.	GENERAL SPECIFICATIONS -----	1
2.	MECHANICAL SPECIFICATIONS -----	1
3.	ABSOLUTE MAXIMUM RATINGS -----	2
4.	ELECTRICAL CHARACTERISTICS -----	3
5.	OPTICAL CHARACTERISTICS -----	4
6.	OUTLINE DIMENSION -----	5
7.	BLOCK DIAGRAM -----	6
8.	DETAIL DRAWING OF DOT MATRIX -----	7
9.	INTERFACE SIGNALS -----	7
10.	POWER SUPPLY -----	8

1. GENERAL SPECIFICATIONS

1.1 GENERAL SPECIFICATIONS

PLEASE REFER TO :

CUSTOMER ACCEPTANCE STANDARD SPECIFICATIONS :

E U - 0 0 2 A

1.2 APPLICATION NOTES FOR CONTROLLER : T6963C

PLEASE REFER TO :

CUSTOMER ACCEPTANCE STANDARD SPECIFICATIONS :

E U - T 6 9 6 3 C

1.3 THIS INDIVIDUAL SPECIFICATION IS PRIOR TO GENERAL SPECIFICATIONS .

2. MECHANICAL SPECIFICATIONS

- | | | |
|--------------------|-------|------------------------------|
| (1) NUMBER OF DOTS | ----- | 240W * 128H DOTS |
| (2) MODULE SIZE | ----- | 170.0W * 103.0H * 14.0D mm |
| (3) EFFECTIVE AREA | ----- | 126.0W * 70.0H mm |
| (4) ACTIVE AREA | ----- | 119.97W * 63.97H mm |
| (5) DOT SIZE | ----- | 0.47W * 0.47H mm |
| (6) DOT PITCH | ----- | 0.50W * 0.50H mm |
| (7) LCD TYPE* | | |
| (8) DRIVING METHOD | ----- | 1 / 128 DUTY MULTIPLEX DRIVE |
| (9) BACKLIGHT | ----- | CCFL |

* PLEASE REFER TO NUMBERING SYSTEM.

3. ABSOLUTE MAXIMUM RATINGS

3.1 ELECTRICAL ABSOLUTE MAXIMUM RATINGS .

PARAMETER	SYMBOL	MIN .	MAX .	UNIT	REMARK
POWER SUPPLY FOR LOGIC	VDD - VSS	0	7.0	V	
LCD DRIVER CIRCUIT SUPPLY VOLTAGE	VDD - VEE	0	28.0	V	
INPUT VOLTAGE	VI	VSS	VDD	V	
STATIC ELECTRICITY	—	—	100	V	NOTE (1)

NOTE (1) : TEST METHOD AND CONDITIONS :

AFTER CHARGING UP 200 PF CAPACITOR BY STATED VOLTAGE ,
THE CAPACITOR IS CONNECTED WITH INTERFACE PINS OF THE
MODULE .

3.2 ENVIRONMENTAL ABSOLUTE MAXIMUM RATINGS .

I T E M	OPERATING		STORAGE		REMARK
	MIN .	MAX .	MIN .	MAX .	
AMBIENT TEMPERATURE	- 20 °C	70 °C	- 30 °C	80 °C	NOTE (2), (3), (4)
HUMIDITY	—	90 % RH	—	90 % RH	WITHOUT CONDENSATION
VIBRATION	—	2.45 m/s ² (0.25 G)	—	11.76 m/s ² (1.2 G)	10 ~ 100 HZ XYZ DIRECTIONS 1 Hr. EACH
SHOCK	—	29.4 m/s ² (3 G)	—	490.0 m/s ² (50 G)	10 mSECONDS XYZ DIRECTIONS 1 TIME EACH
CORROSIVE GAS	NOT ACCEPTABLE		NOT ACCEPTABLE		

NOTE (2) : Ta AT -30°C : 48HR MAX .

80°C : 168HR MAX .

NOTE (3) : BACKGROUND COLOR CHANGES SLIGHTLY DEPENDING ON AMBIENT
TEMPERATURE THIS PHENOMENON IS REVERSIBLE .

NOTE (4) CCFL BACKLIGHT IS NOT AVAILABLE TO FUNCTION BELOW 0°C .

4 . ELECTRICAL CHARACTERISTICS

Ta = 25 °C

VDD = 5.0 V

PARAMETER		SYMBOL	CONDITION	MIN .	TYP .	MAX .	UNIT
POWER SUPPLY VOLTAGE FOR LOGIC		VDD - VSS	—	4.5	5.0	5.5	V
POWER SUPPLY VOLTAGE FOR LCD DRIVE		VEE - VSS	—	—	-13.5	-22.5	V
INPUT VOLTAGE NOTE (1)	VIH	H LEVEL	VDD-2.2	—	VDD	V	
	VIL	L LEVEL	0	—	0.8	V	
OUTPUT VOLTAGE NOTE (1)	VIH	H LEVEL	VDD-0.3	—	VDD	V	
	VIL	L LEVEL	0	—	0.3	V	
POWER SUPPLY CURRENT FOR LOGIC NOTE (2)		IDD	VDD - VSS = 5.0 V VEE - VSS = -13.5 V	—	9.0	24.0	mA
POWER SUPPLY CURRENT FOR LCD DRIVE NOTE (2)		IEE	VDD - VSS = 5.0 V VEE - VSS = -13.5 V	—	2.0	5.0	mA
RECOMMENDED LCD DRIVING VOLTAGE NOTE (3)	VDD - VEE ∅ = 10° θ = 0°	Ta = -20 °C	—	18.5	—	V	
		Ta = 25 °C	—	18.5	—	V	
		Ta = 70 °C	—	15.5	—	V	
CLOCK OSCILLATION FREQUENCY		f _{osc}	—	—	6.0	—	MHZ
POWER SUPPLY FOR CCFL	VOLTAGE FREQUENCY CURRENT	VCCFL	—	—	300	—	V _{rms}
		fCCFL	—	—	30K	—	HZ
		IL	—	—	5	—	mA

NOTE (1): APPLIED TO TERMINALS \overline{WR} , \overline{RD} , \overline{CE} , $\overline{C/D}$, \overline{RST} , \overline{FS} , $\overline{DB0}$ ~ $\overline{DB7}$.

NOTE (2): THE DISPLAY PATTERN IS ALL "OFF" / "ON".

NOTE (3): RECOMMENDED LCD DRIVING VOLTAGE MAY FLUCTUATE ABOUT ±1.0V BY EACH MODULE.

5. OPTICAL CHARACTERISTICS

Ta = 25 °C VDD = 5.0 V

I T E M		SYMBOL	CONDITION	MIN .	TYP .	MAX.	UNIT	NOTE
VIEWING ANGLE	STN	∅ 2 - ∅ 1	K ≥ 1.4	—	40	—	deg .	1
	FSTN			—	50	—	deg .	1
CONTRAST RATIO	STN	K	∅ = 10° θ = 0°	—	10	—	—	1
	FSTN			—	20	—	—	1
RESPONSE TIME	tr (rise)	∅ = 10° θ = 0°	Ta = -20°C	—	5538	—	ms	1
			Ta = 25°C	—	228	—		
			Ta = 70°C	—	104	—		
	tf (fall)		Ta = -20°C	—	2316	—		
			Ta = 25°C	—	174	—		
			Ta = 70°C	—	85	—		
AVERAGE BRIGHTNESS OF BACKLIGHT	B	—	460	580	—	cd / m ²	2, 3	
RISE TIME OF BACKLIGHT	TC	—	—	5	—	MINUTE		
BRIGHTNESS UNIFORMITY	—	—	—	—	—	25	%	4, 5

NOTE (1) : PLEASE REFER TO :
 CUSTOMER ACCEPTANCE STANDARD SPECIFICATIONS.
 E U - 0 0 2 A

NOTE (2) : MEASUREMENT AFTER 10 MINUTES OF CCFL OPERATING .

NOTE (3) : BRIGHTNESS CONTROL : 100% AND DISPLAY ALL ON .

NOTE (4) : MEASUREMENT OF THE FOLLOWING 9 PLACES ON THE DISPLAY.
 DEFINITION OF THE BRIGHTNESS UNIFORMITY.

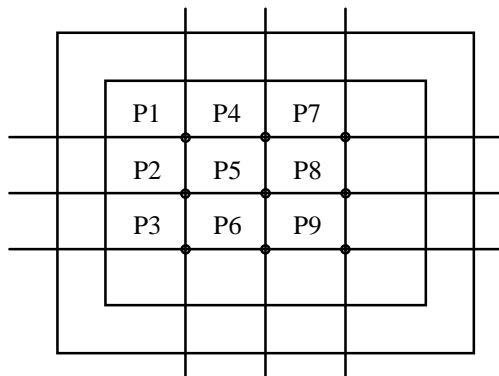

NOTE (5) : BRIGHTNESS UNIFORMITY IS DEFINED AS FOLLOWING

$$\sum X = \left[\frac{(\text{MAXIMUN BRIGHTNESS OR MINIMUN BRIGHTNESS}) - \text{AVERAGE BRIGHTNESS}}{\text{AVERAGE BRIGHTNESS}} \right] \times 100\%$$

MODEL NO .	VERSION	PAGE
24D70 (CCFL TYPES)	2	5

6. OUTLINE DIMENSION

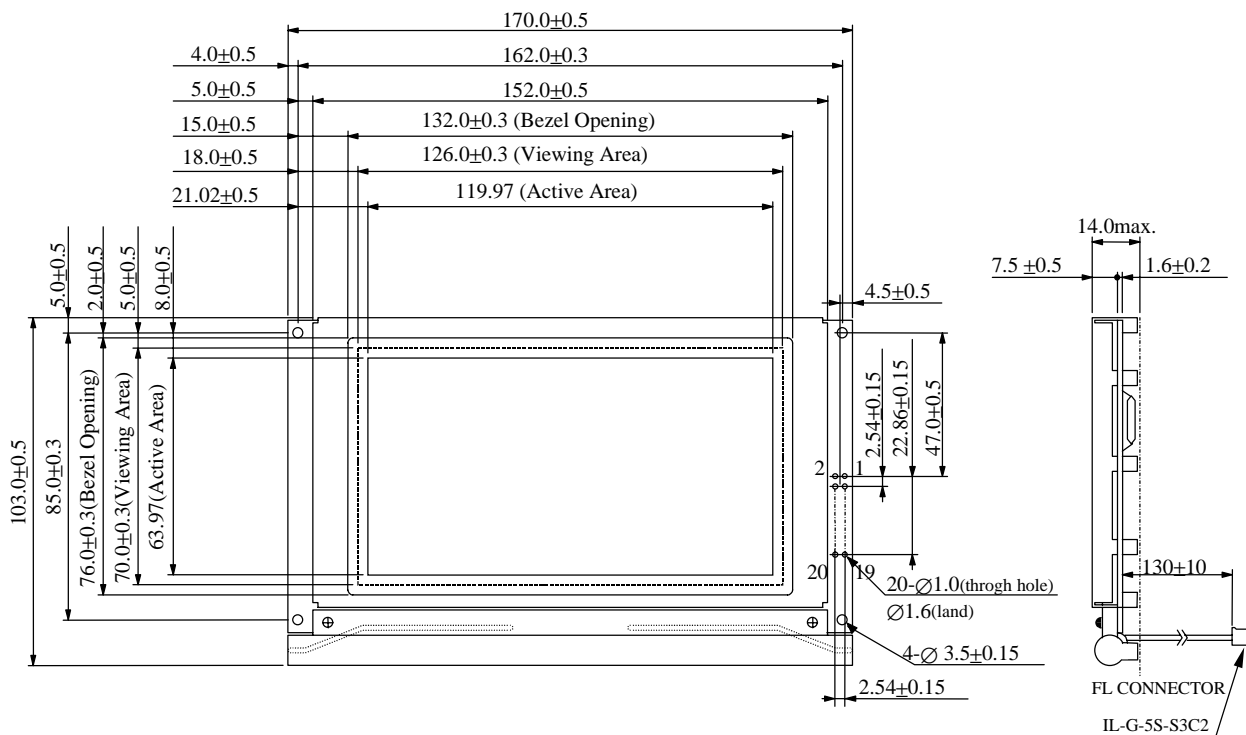

UNIT : mm
 SCALE : NTS
 NOT SPECIFIED TOLERANCE IS±0.5mm

7. BLOCK DIAGRAM

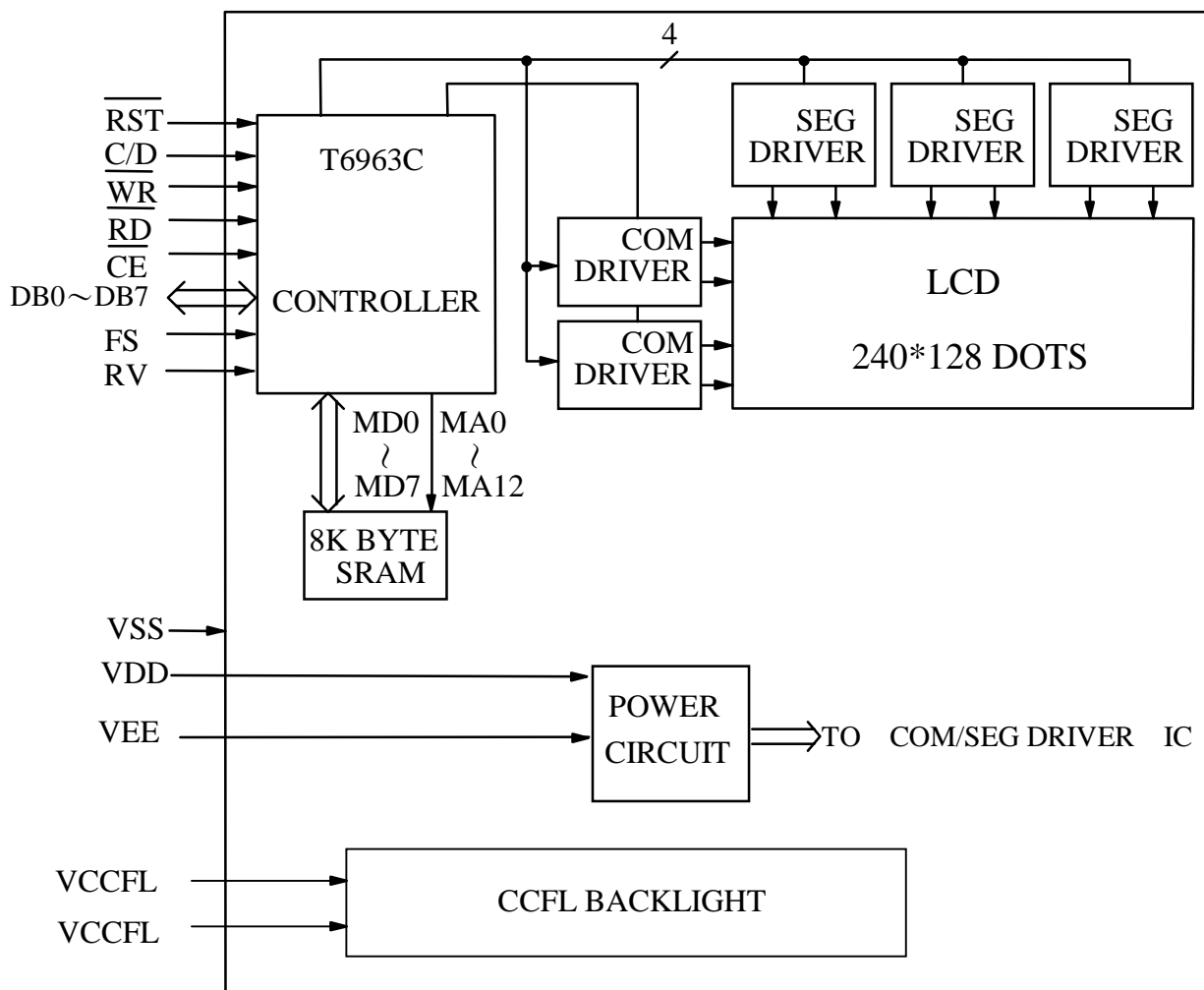

8. DETAIL DRAWING OF DOT MATRIX

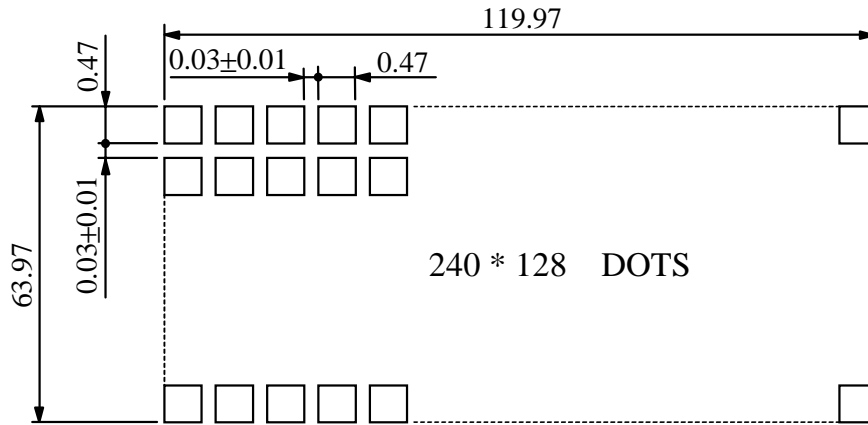

UNIT : mm
 SCALE : NTS
 NOT SPECIFIED TOLERANCE IS ± 0.1

9. INTERFACE SIGNALS

PIN NO	SYMBOL	LEVEL	FUNCTION
1	FGND	—	FRAME GROUND
2	GND	—	GROUND
3	VDD	—	POWER SUPPLY FOR LOGIC CIRCUIT
4	VEE	—	POWER SUPPLY FOR LCD DRIVING
5	$\overline{\text{WR}}$	L	DATA WRITE
6	$\overline{\text{RD}}$	L	DATA READ
7	$\overline{\text{CE}}$	H	CHIP ENABLE
8	$\overline{\text{C/D}}$	H/L	$\overline{\text{WR}}=\text{“L”}, \overline{\text{C/D}}=\text{“H”}$: COMMAND WRITE $\overline{\text{C/D}}=\text{“L”}$: DATA WRITE $\overline{\text{RD}}=\text{“L”}, \overline{\text{C/D}}=\text{“H”}$: STATUS READ $\overline{\text{C/D}}=\text{“L”}$: DATA READ
9	N.C.	—	NO CONNECTION
10	$\overline{\text{RST}}$	L	RESET
11 18	DB0 DB7	H/L	DATA BUS LINE
19	FS	H/L	SELECT : “H” : 6*8 PIXEL/FONT “L” : 8*8 PIXEL/FONT
20	RV	H/L	H: BLACK CHARACTERS L : WHITE CHARACTERS

10. POWER SUPPLY

10.1 POWER SUPPLY FOR LCM

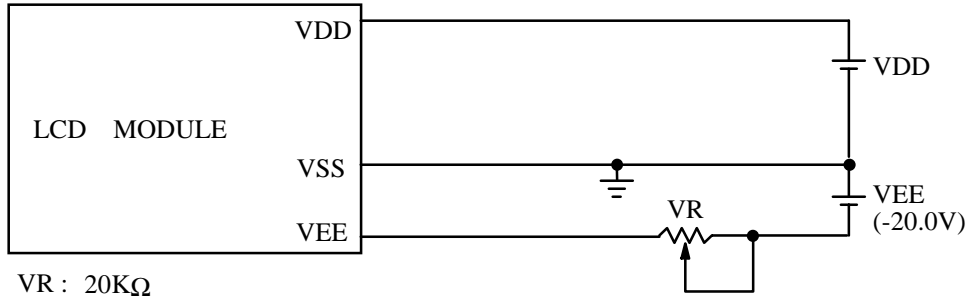

10.2 POWER SUPPLY FOR CCFL BACK - LIGHT

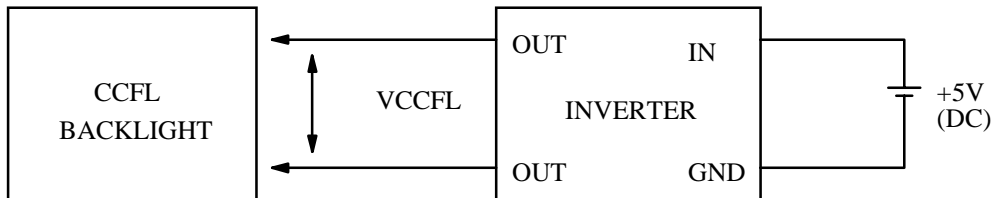

RECOMMENDED INVERTER : IA-EM04A

10.2 TIMING OF POWER SUPPLY AND INTERFACE SIGNAL

