

EXAMINED BY :  <i>Jony Chen</i>	<p style="text-align: center;"><b>MITSUTECH</b></p> <p style="text-align: center;">INTERNATIONAL CORPORATION</p>	FILE NO . CAS-10210
APPROVED BY :  <i>David Chang</i>		ISSUE : APR.05,2000
		TOTAL PAGE : 10
		VERSION : 1

CUSTOMER	ACCEPTANCE	SPECIFICATIONS
----------	------------	----------------

MODEL NO . :

32F50(LED TYPES)

FOR MESSRS :

\_\_\_\_\_

CUSTOMER'S APPROVAL

DATE :

\_\_\_\_\_

BY :

\_\_\_\_\_

MITSUTECH INT'L CORP.

MODEL NO . 32F50(LED TYPES)	VERSION 1
--------------------------------	--------------

RECORDS OF REVISION	DOC . FIRST ISSUE APR.05,2000
---------------------	----------------------------------

DATE	REVISED PAGE NO.	SUMMARY

TABLE OF CONTENTS

NO.	ITEM	PAGE
1.	GENERAL SPECIFICATIONS -----	1
2.	MECHANICAL SPECIFICATIONS -----	1
3.	ABSOLUTE MAXIMUM RATINGS -----	2
4.	ELECTRICAL CHARACTERISTICS -----	3
5.	TIMING CHARACTERISTICS -----	4~5
6.	OPTICAL CHARACTERISTICS -----	6
7.	OUTLINE DIMENSION -----	7
8.	BLOCK DIAGRAM -----	8
9.	DETAIL DRAWING OF DOT MATRIX -----	9
10.	INTERFACE SIGNALS -----	9
11.	POWER SUPPLY -----	10

MODEL NO.	VERSION
32F50(LED TYPES)	1

NUMBERING SYSTEM

Polarizer	Mode	Backlight	Code value
Transflective		LED	L

E W 32 F 50 G L Y

LCD type + color	Code Value
STN + Yellow-Green	Y
STN + Gray	G
FSTN + White	F

Backlight	Code value
Yellow-Green	Y

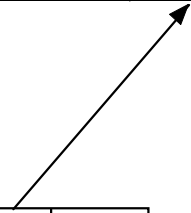
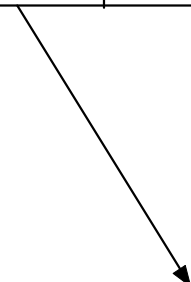

MODEL NO .	VERSION	PAGE
32F50(LED TYPES)	1	1

1. GENERAL SPECIFICATIONS

1.1 GENERAL SPECIFICATIONS

PLEASE REFER TO :

CUSTOMER ACCEPTANCE STANDARD SPECIFICATIONS :

E U - 0 0 1 A

1.2 THIS INDIVIDUAL SPECIFICATION IS PRIOR TO GENERAL SPECIFICATIONS .

2. MECHANICAL SPECIFICATIONS

- (1) NUMBER OF DOTS ----- 320W \* 240H DOTS
- (2) MODULE SIZE ----- 134.5W \* 117.0H \* 14.0D(max.)mm
- (3) EFFECTIVE AREA ----- 103.0W \* 79.0H mm
- (4) ACTIVE AREA ----- 95.97W \* 71.97H mm
- (5) DOT SIZE ----- 0.27W \* 0.27H mm
- (6) DOT PITCH ----- 0.3W \* 0.3H mm
- (7) LCD TYPE \*
- (8) DRIVING METHOD ----- 1 / 240 DUTY MULTIPLEX DRIVE
- (9) BACKLIGHT ----- LED , COLOR : YELLOW-GREEN
- (10) TEMPERATURE COMPENSATION CIRCUIT IS BUILT IN

\* PLEASE REFER TO NUMBERING SYSTEM .

### 3. ABSOLUTE MAXIMUM RATINGS

#### 3.1 ELECTRICAL ABSOLUTE MAXIMUM RATINGS .

PARAMETER	SYMBOL	MIN .	MAX .	UNIT	REMARK
POWER SUPPLY FOR LOGIC	VDD - VSS	0	7.0	V	
POWER SUPPLY FOR LCD DRIVING	VDD - VEE	0	3.5	V	
INPUT VOLTAGE	VI	VSS	VDD	V	
STATIC ELECTRICITY	—	—	100	V	NOTE (1)
LED POWER VOLTAGE	VLED	—	2.7	V	
LED FORWARD CURRENT	IF	—	80	mA	

NOTE (1) : TEST METHOD AND CONDITIONS :  
 AFTER CHARGING UP 200 PF CAPACITOR BY STATED VOLTAGE ,  
 THE CAPACITOR IS CONNECTED WITH INTERFACE PINS OF THE  
 MODULE .

#### 3.2 ENVIRONMENTAL ABSOLUTE MAXIMUM RATINGS .

I T E M	OPERATING		STORAGE		REMARK
	MIN .	MAX .	MIN .	MAX .	
AMBIENT TEMPERATURE	-20 °C	70 °C	-30 °C	80 °C	NOTE (2), (3)
HUMIDITY	—	90 % RH	—	90 % RH	WITHOUT CONDENSATION
VIBRATION	—	2.45 m/s <sup>2</sup> (0.25 G)	—	11.76 m/s <sup>2</sup> (1.2 G)	10 ~ 100 HZ XYZ DIRECTIONS 1 Hr. EACH
SHOCK	—	29.4 m/s <sup>2</sup> (3 G)	—	490.0 m/s <sup>2</sup> (50 G)	10 mSECONDS XYZ DIRECTIONS 1 TIME EACH
CORROSIVE GAS	NOT ACCEPTABLE		NOT ACCEPTABLE		

NOTE (2) : Ta AT -30°C : 48HR MAX .  
 80°C : 168HR MAX .

NOTE (3) : BACKGROUND COLOR CHANGES SLIGHTLY DEPENDING ON AMBIENT  
 TEMPERATURE THIS PHENOMENON IS REVERSIBLE .

## 4. ELECTRICAL CHARACTERISTICS

Ta = 25 °C

VDD = 5.0 V

PARAMETER	SYMBOL	CONDITION	MIN .	TYP .	MAX .	UNIT
POWER SUPPLY VOLTAGE FOR LOGIC	VDD - VSS	—	4.5	5.0	5.5	V
POWER SUPPLY VOLTAGE FOR LCD DRIVE	VEE - VSS	—	-26.5	-27.0	-27.5	V
INPUT VOLTAGE NOTE (1)	VIH	H LEVEL	0.8*VDD	—	—	V
	VIL	L LEVEL	—	—	0.2*VDD	V
POWER SUPPLY CURRENT FOR LOGIC	IDD	VDD - VSS = 5.0 V VEE - VSS = -27.0	—	4	8	mA
POWER SUPPLY CURRENT FOR LCD DRIVE	IEE	VDD - VSS = 5.0 V VEE - VSS = -27.0	—	5	10	mA
RECOMMENDED LCD DRIVING VOLTAGE NOTE (2)	VDD - VLCD ∅ = 10° θ = 0°	Ta = -20 °C	—	24.3	—	V
		Ta = 25 °C	—	20.0	—	V
		Ta = 70 °C	—	15.8	—	V
	VDD - VO	Ta = 25 °C	—	14	—	V
FLM FREQUENCY	f FLM	—	70	75	80	HZ
POWER SUPPLY FOR LED	VLED	—	21	24	27	V
	ILED	VLED = 24V	—	40	50	mA

NOTE (1): APPLIED TO TERMINALS M, FLM, CL1, CL2, D0 ~ D3, DISPOFF .

NOTE (2): RECOMMENDED LCD DRIVING VOLTAGE MAY FLUCTUATE ABOUT ± 1.0V BY EACH MODULE .

5. TIMING CHARACTERISTICS  
5.1 INTERFACE TIMING

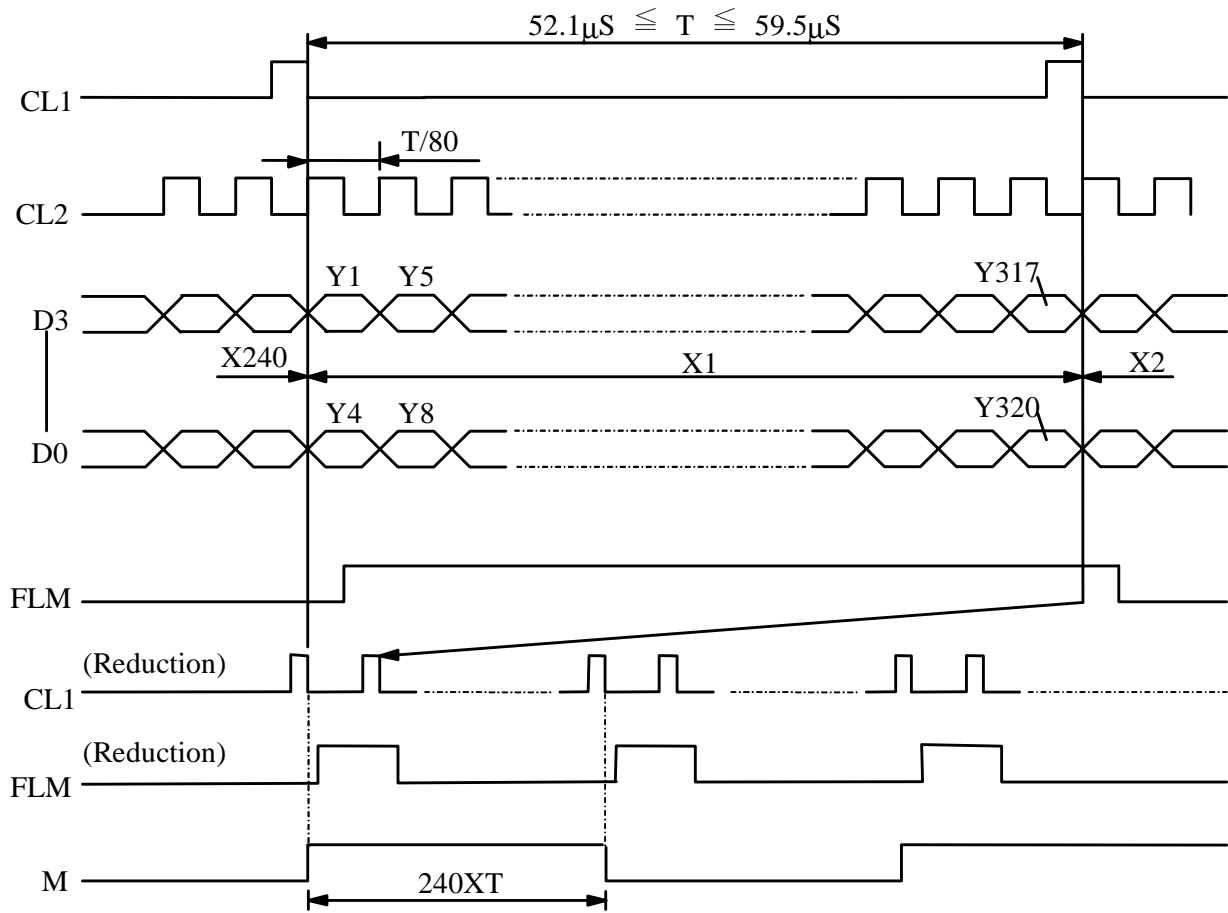

5.2 SWITCHING CHARACTERISTICS

PARAMETER	SYMBOL	MIN.	TYP.	MAX.	UNIT
Frequency of maximum clock	fcp	—	—	8	MHZ
CL1 , CL2 , pulse width	tw	45	—	—	ns
Rise , fall time	tr,tf	—	—	15	ns
Data setup time	tDSU	20	—	—	ns
Data hold time	tDHD	20	—	—	ns
CL1 setup time	tLSU	80	—	—	ns
CL1 → CL2 time	tLC	80	—	—	ns
FLM setup time	tsetup	100	—	—	ns
FLM hold time	t hold	100	—	—	ns
M delay time	tDF	—	—	300	ns

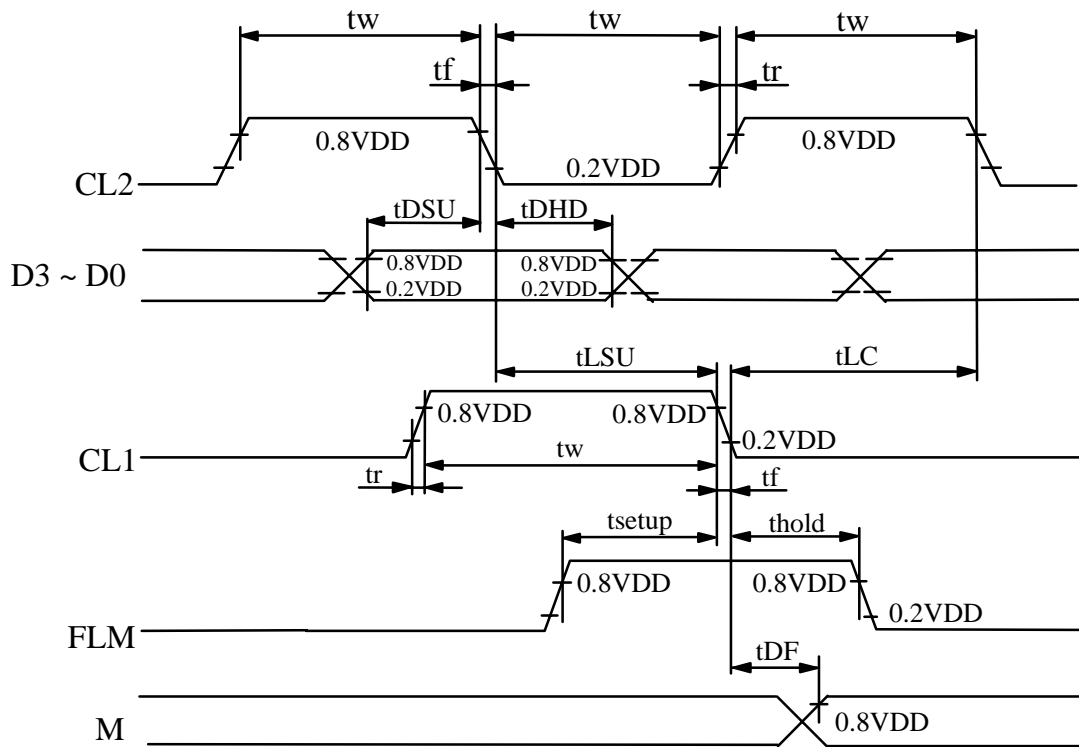

6. OPTICAL CHARACTERISTICS

Ta = 25 °C

VDD = 5.0 V

VDD-VLCD = (22.7V)

I T E M		SYMBOL	CONDITION	MIN .	TYP .	MAX.	UNIT	NOTE
VIEWING AREA	STN	∅ 2 - ∅ 1	K ≥ 2.0	—	40	—	deg .	1
	FSTN			—	50	—	deg .	1
CONTRAST RATIO	STN	K	∅ = 10° θ = 0°	—	10	—	—	1
	FSTN			—	20	—	—	1
RESPONSE TIME	tr ( rise )	∅=10° θ = 0°	Ta = 20 °C	—	6268	—	ms	1
			Ta = 25 °C	—	228	—		
			Ta = 70 °C	—	104	—		
	tf ( fall )		Ta = 20 °C	—	5714	—		
			Ta = 25 °C	—	191	—		
			Ta = 70 °C	—	86	—		
BRIGHTNESS OF BACKLIGHT		B	—	—	3.5	—	cd / m²	—

NOTE (1) : PLEASE REFER TO :  
CUSTOMER ACCEPTANCE STANDARD SPECIFICATIONS.

EU - 001 A

MODEL NO . 32F50(LED TYPES)	VERSION 1	PAGE 7
--------------------------------	--------------	-----------

7. OUTLINE DIMENSION

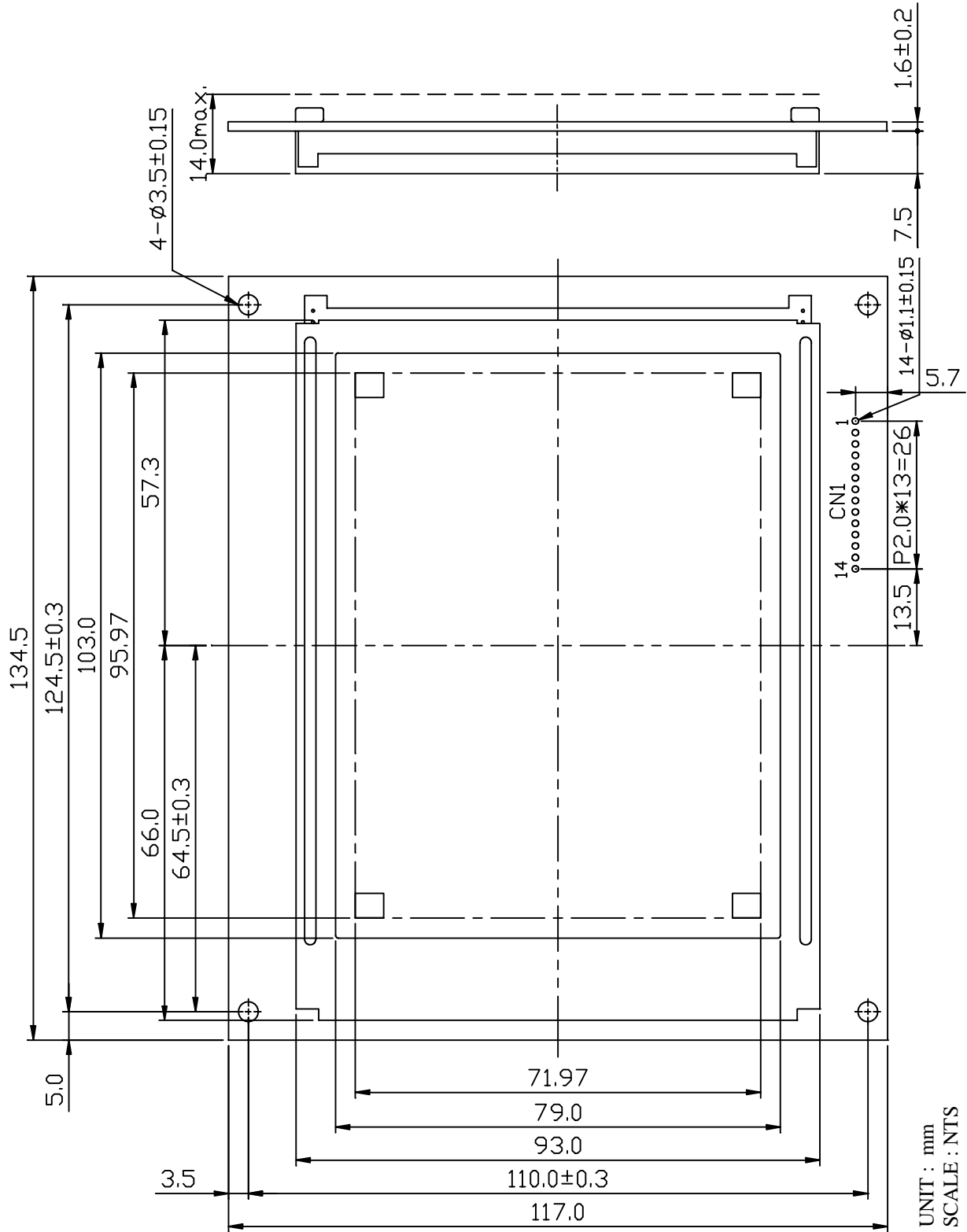

UNIT : mm  
 SCALE : NTS  
 NOT SPECIFIED TOLERANCE IS ± 0.5

8. BLOCK DIAGRAM

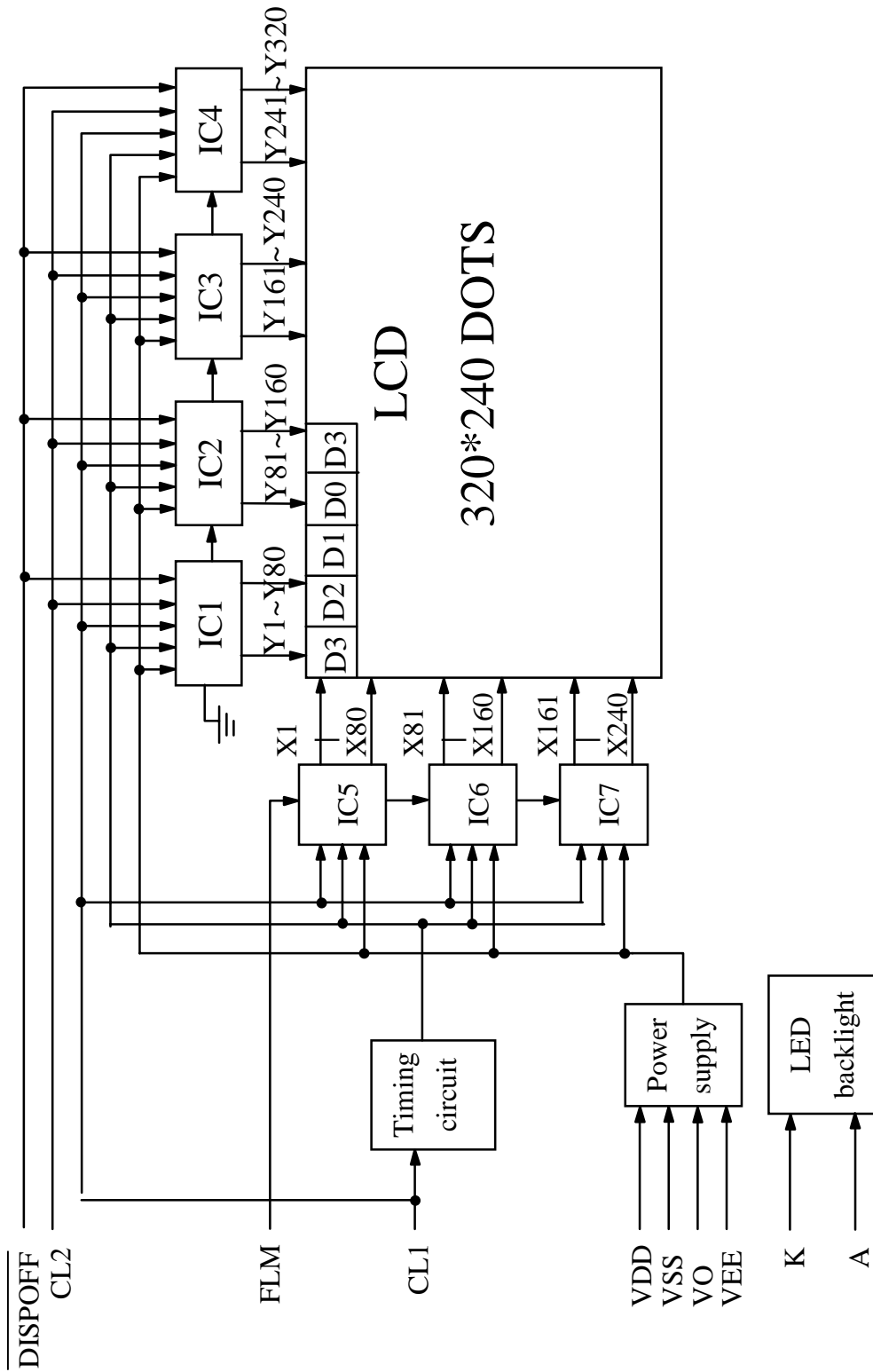

9. DETAIL DRAWING OF DOT MATRIX

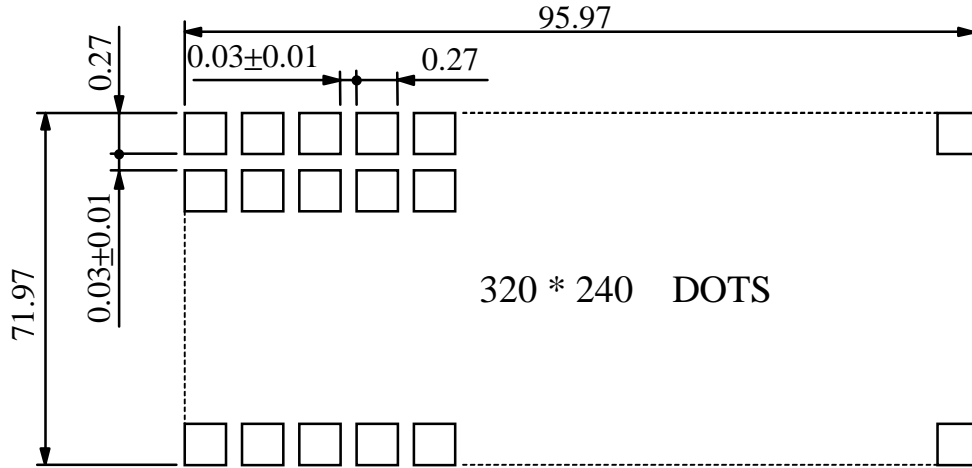

UNIT : mm  
 SCALE : NTS  
 NOT SPECIFIED TOLERANCE IS ± 0.1

10. INTERFACE SIGNALS

PIN NO	SYMBOL	LEVEL	FUNCTION
1	VO	—	OPERATING VOLTAGE FOR LCD DRIVING
2	VEE	—	POWER SUPPLY FOR LCD DRIVING ( -27V )
3	D3	H / L	DISPLAY DATA
4	D2	H / L	
5	D1	H / L	
6	D0	H / L	
7	VSS	—	GROUND
8	VDD	—	POWER SUPPLY FOR LOGIC CIRCUIT
9	CL2	H → L	DISPLAY DATA SHIFT
10	CL1	H → L	DISPLAY DATA LATCH
11	FLM	H	THE FLM SIGNAL INDICATING THE BEGINNING OF EACH DISPLAY CYCLE
12	K	—	POWER SUPPLY FOR LED BACKLIGHT ( GND )
13	A	—	POWER SUPPLY FOR LED BACKLIGHT ( +24V )
14	NC	—	NO CONNECTION

1 1 . POWER SUPPLY

1 1 . 1 POWER SUPPLY FOR LCM

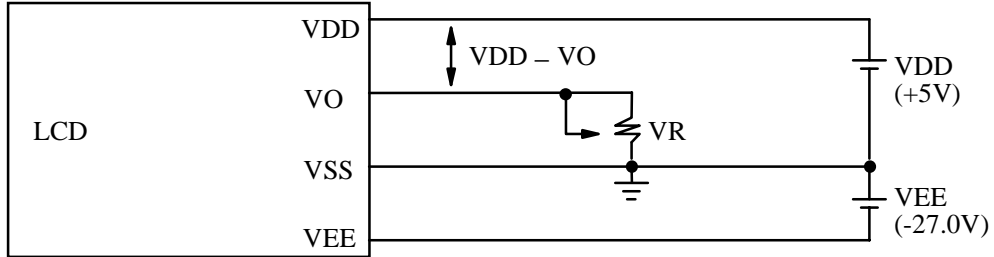

VDD - VO : LCD DRIVING VOLTAGE  
VR : 30KΩ ~ 50KΩ

1 1 . 2 POWER SUPPLY FOR LED BACK - LIGHT

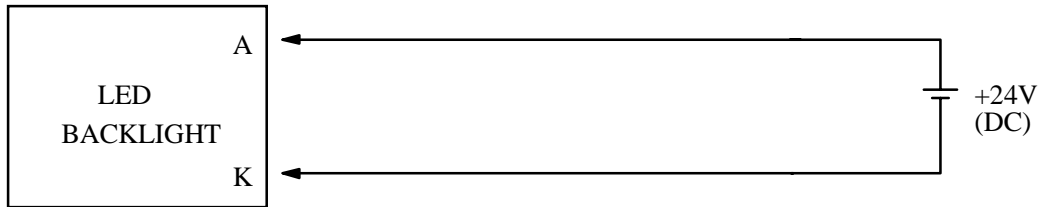

1 1 . 3 TIMING OF POWER SUPPLY AND INTERFACE SIGNAL

